

Accessories

North America Price List – December 2025



Electronic Update Page – Accessories Price Book

- The table below lists all of the updates and addendums added to this price list since the original version was created.
- All **Update** pages will replace the existing pages within the document.
- All **New** pages will be placed at the back of the document.

Link	Date	Pages	Description
Click Here	February 2026	61, 63	Update – Two Tool Rails were obsoleted.
Click Here	April 2026	14-19	Update – Belong Monitors Arms have been added to the GSA Contract.
Click Here	May 2026	86	Update – Knob Right option added for X Series Attached, Suspended, Mobile Pedestals



This Haworth North American price book contains US list prices.

Canadian customers can convert the US list price into their Canadian equivalent by going to www.Haworth.com/Canada to find the current Canadian multipliers. These multiplier factors allow you to convert the US list price into a Canadian list price.



This Page Intentionally Left Blank

Accessories Price List

Includes pricing, catalog numbers, finish codes/availability, specification requirements, line art, dimensions, and specification tips for Accessories.

Belong Monitor Arms

Ergotron Monitor Arms

Ergotron Monitor Mount

Ergotron Sit-Stand Workstation

Ergotron Standing Workstation

Ergotron Accessories

Ergotron Mobile Cart

Ergotron Laptop Cart

Ergotron Mobile Digital Workstation

Ergotron Keyboard & CPU Holder

Lighting

Storage & Accessories

Work Tools

Workstation Accessories

Waste Solutions

Lock Programs

Table of Contents

Price List

Statement of Line	8
Belong Monitor Arm	
Single — Single Monitor Arm	14
Single with Crossbar — Single Monitor Arm with Crossbar	15
Dual — Dual Monitor Arm	16
Accessories — Belong Techbase	17
Accessories — Wire Manager Cover	17
Accessories — Grommet Mount Base	17
Accessories — Crossbar & Handle Kit	18
Accessories — Single Handle Kit	18
Accessories — VESA Slider Kit	18
Accessories — Single to Dual Conversion Kit	19
Accessories — Triple Conversion Kit	19
Ergotron Monitor Arms	
MX — Desk Mount - Single Arm	20
MX — Wall Mount - Heavy Duty	20
MXV Desk Mount — Single Arm	21
MXV Desk Mount — Dual Arm	21
MXV Accessories — Grommet Mount for MXV Single Monitor Arm	22
MXV Accessories — Grommet Mount for MXV Dual Monitor Arm	22
HX Desk Mount — Single Arm	23
HX Desk Mount — Dual Arm	23
HX Accessories — Triple Monitor Blow Kit	24
Accessories — Dual Monitor and Handle Kit	25
Accessories — Monitor Quick Release LCD Bracket	25
Accessories — Top Mount Low Profile C-Clamp	25
Ergotron Monitor Mount	
TRACE — Single Monitor	26
TRACE — Dual Monitor	27
TRACE Accessories — Single Conversion Kit	28
TRACE Accessories — Dual Conversion Kit	28
Ergotron Sit-Stand Workstation	
WorkFit A — Dual Attached	29
WorkFit-S — Single Attached	30
WorkFit-S — Dual Attached	30
WorkFit-T — Desktop	31
WorkFit-TL — Desktop	32
WorkFit-Z Mini	33
WorkFit-TX	34
WorkFit Corner	35
Ergotron Accessories	
WorkFit-A / WorkFit-S — Conversion Kit: Dual to LCD & Laptop	36
WorkFit-A / WorkFit-S — Conversion Kit: LCD & Laptop to Dual	36
WorkFit-A / WorkFit-S — Tall-User Kit for WorkFit Dual	36
WorkFit-A / WorkFit-S — Corner Keyboard Tray	37
WorkFit-A / WorkFit-S — Grommet Mount	37
WorkFit-A / WorkFit-S — Dual Monitor Double-Hinged Bow	37
WorkFit-T/WorkFit-TL — WorkFit Single LCD Monitor Kit	38
WorkFit-T/WorkFit-TL — WorkFit Dual Monitor Kit	38
Ergotron Mobile Cart	
WorkFit-C	39
LearnFit — LearnFit Desk	40
LearnFit — Storage Bin	40
Ergotron Laptop Cart	
Neo-Flex	41
Ergotron Mobile Digital Workspace	
Teachwell®	42
Ergotron Keyboard Tray	
Keyboard Tray with Mouse Pad	43
Neo-Flex Keyboard Tray	43
Ergotron CPU Holder	
Small CPU Holder	44
Universal CPU Holder	44
Cable CPU Holder	44
Anti-Fatigue Floor Mat	44

Lighting

Task — Adjustable LED Task Light – Stand-Alone	45
Task — Adaptable LED Task Light – Starter Kit	45
Task — Adaptable LED Task Light – Add-On Kit	46
Reed Premier™ — Stand-Alone LED Task Light	47
Reed Premier™ — Starter LED Task Light	47
Reed Premier™ — Task Light Add-On Kit	48
Reed Premier™ — Add-On Occupancy Sensor	48
Voyage — Without Occupancy Sensor	49
Voyage — With Occupancy Sensor	49

Storage — Suspended

Belong — Suspended Pedestal	50
Belong — Security Drawer	51

Storage — Suspended Accessories

Belong — Top Liner — Security Drawer	52
Belong — Drawer Liner	52
Belong — File Partition	52
Belong — Drawer Tray	52

Storage Accessories

Belong — PDA Tray	53
Belong — Personal Tray	53
Belong — Pencil Tray	53
Belong — Magnetic Divider	53
Belong — Cushion Top	54

Work Tools

Rails and Mounting — Slat, Wall Mount	55
Rails and Mounting — Single Side	56
Rails and Mounting — Tool Rail — Horizontal Surface Mount	
C-Clamp or Thru-Mount	57
Rails and Mounting — Tool Rail — Single Post — C-Clamp or	
Thru-mount	58
Rails and Mounting — Tool Rail — Single Post — L-Bracket Mount	58
Rails and Mounting — Tool Rail — Under Horizontal Surface	
Mount — L-Bracket	59
Rails and Mounting — Tool Rail — Single Sided Continuous	
Benching End	60
Rails and Mounting — Tool Rail — Double-Sided Continuous	
Benching End Application Only	61
Rails and Mounting — Tool Rail — Internal Single Sided	
Continuous Benching Application	62
Rails and Mounting — Tool Rail — Internal Continuous Benching	
Application Only	63
Rails and Mounting — Tool Rail — Single Post Internal/Benching	63
Belong — Open C Cubby	64
Belong — Blotter	64
Belong — Reference Shelves	64
Belong — Base Tray	65
Belong — Desk Top L-Screen	65
Belong — Desk Top Reference Shelf	65
Belong — Trays	66
Belong — Paper Tray — Landscape	66
Belong — Mini Shelf	66
Belong — Accessory Kit	67
Belong — Tool Cup	67
Belong — Hanging Sorter	67
Jump Stuff — Paper Sorter	68
Jump Stuff — Binder Bin	68
Jump Stuff — Mini Shelf	68
Jump Stuff — Phone Shelf	68
Jump Stuff — Letter Tray	69
Jump Stuff — Waste Bin	69
Magnetic Accessories — Magnet Hooks	70
Magnetic Accessories — Magnet Hook	70
Magnetic Accessories — Mirror	70

Table of Contents

Workstation Accessories

Shallow Drawer	71
Steel Center Drawer	71
Pencil + Drawer	71
Pencil Drawer	72
Make-A-Corner	72
Hooks — Compose All-Purpose Hook	73
Hooks — UniGroup All-Purpose Hook	73
Hooks — UniGroup Too All Purpose Hook	73
Hooks — Bag Hook	73
Markerboard Accessories	74
2/90 Sign Systems	75

Waste Solutions

Recycling Station	76
Recycling/Trash Bin	76

Lock Programs

Specification Guidelines	77
HW Lock Program	78
HW Lock Plugs and Key	80
Keys — HW Plugs and Keys	81
Keys — HW Replacement Keys	81
Keys — HW Master Key	81
Key — HW Control Key	81
Key — HW Key Blank	81
Digital Locks — Digital Lock	82
Digital Locks — Digital Lock Control Key Fob	82
Digital Lock Applications	83
Service Parts	87

Resources

Surface Materials

Finish/Color Legend	89-90
---------------------	-------

Index	91-93
--------------	-------

Lifetime Product Warranty	Inside Back Cover
----------------------------------	-------------------

Statement of Line

Belong Monitor Arms

Pages 14-19

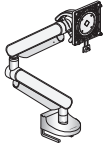

Single Monitor Arm

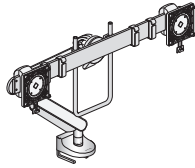

Single Monitor Arm with Crossbar

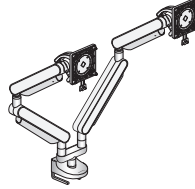

Dual Monitor Arm

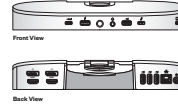
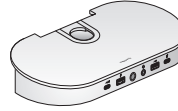

Accessories - Belong Techbase

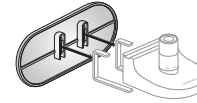

Accessories - Wire Manager Cover

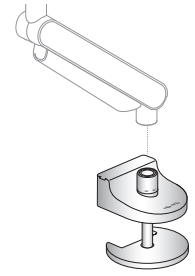

Accessories - Grommet Mount Base

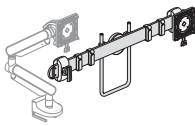

Accessories - Crossbar & Handle Kit

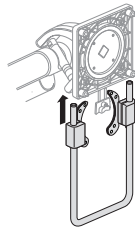

Accessories - Single Handle Kit

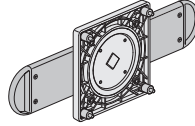

Accessories - VESA Slider Kit

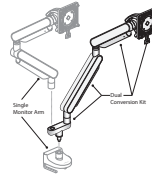

Accessories - Single to Dual Conversion Kit

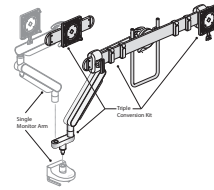

Accessories - Triple Conversion Kit

Ergotron Monitor Arms

Pages 20-25

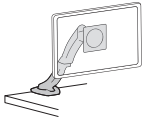

MX Desk Mount Single Arm

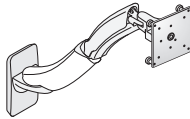

MX Wall Mount Heavy Duty

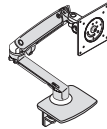

MXV Desk Mount Single Arm

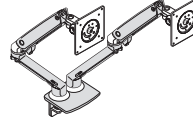

MXV Desk Mount Dual Arm



MXV Accessories Grommet Mount for MXV Single Monitor Arm



MXV Accessories Grommet Mount for MXV Dual Monitor Arm

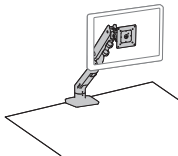

HX Desk Mount Single Arm

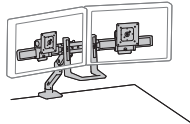

HX Desk Mount Dual Arm

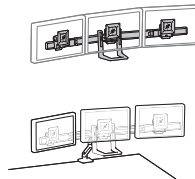

HX Accessories Triple Monitor Blow Kit

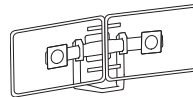

Dual Monitor and Handle Kit



Monitor Quick Release LCD Bracket

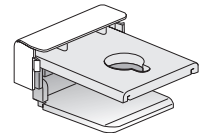

Top Mount Low Profile C-Clamp

Ergotron Monitor Mount

Pages 26-28

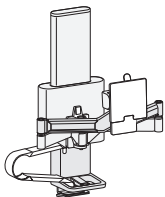

TRACE Single Monitor

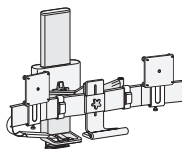

TRACE Dual Monitor

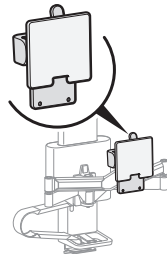

TRACE Single Conversion Kit

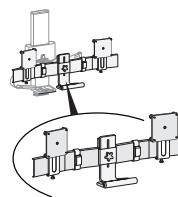

TRACE Dual Conversion Kit

Statement of Line

Ergotron Sit-Stand Workstation

Pages 29-33

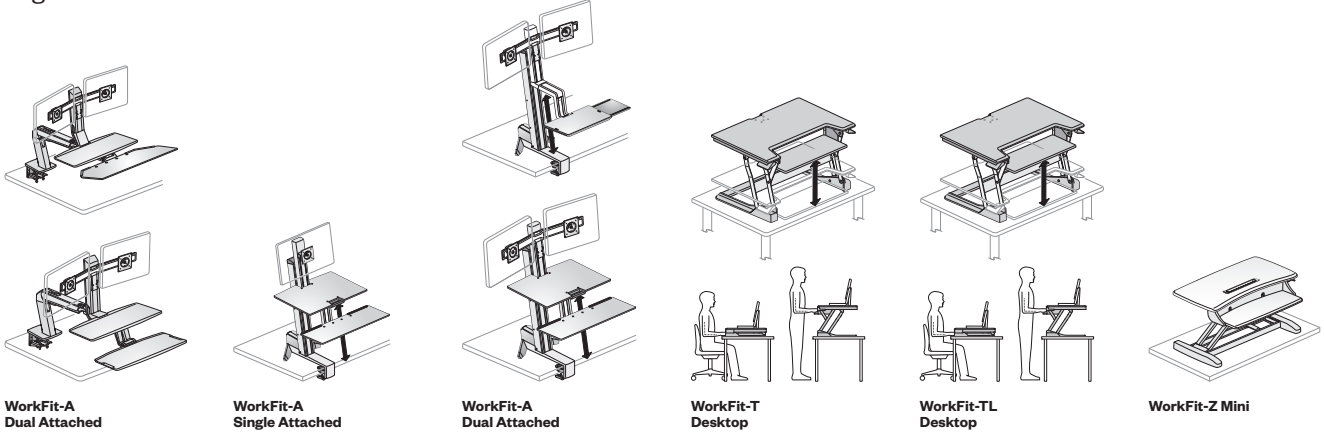

WorkFit-A
Dual Attached

WorkFit-A
Single Attached

WorkFit-A
Dual Attached

WorkFit-T
Desktop

WorkFit-TL
Desktop

WorkFit-Z Mini

Ergotron Standing Workstation

Pages 34-35

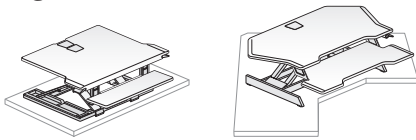

WorkFit-TX

WorkFit Corner

Ergotron Accessories

Pages 36-38

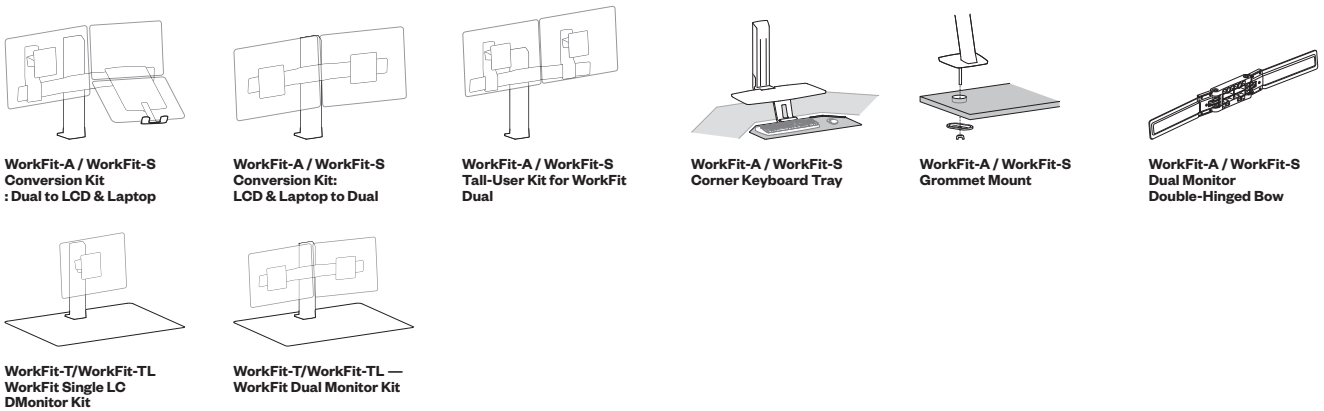

WorkFit-A / WorkFit-S
Conversion Kit
: Dual to LCD & Laptop

WorkFit-A / WorkFit-S
Conversion Kit:
LCD & Laptop to Dual

WorkFit-A / WorkFit-S
Tall-User Kit for WorkFit
Dual

WorkFit-A / WorkFit-S
Corner Keyboard Tray

WorkFit-A / WorkFit-S
Grommet Mount

WorkFit-A / WorkFit-S
Dual Monitor
Double-Hinged Bow

WorkFit-T/WorkFit-TL
WorkFit Single LC
DMonitor Kit

WorkFit-T/WorkFit-TL —
WorkFit Dual Monitor Kit

Ergotron Mobile Cart

Pages 39-40

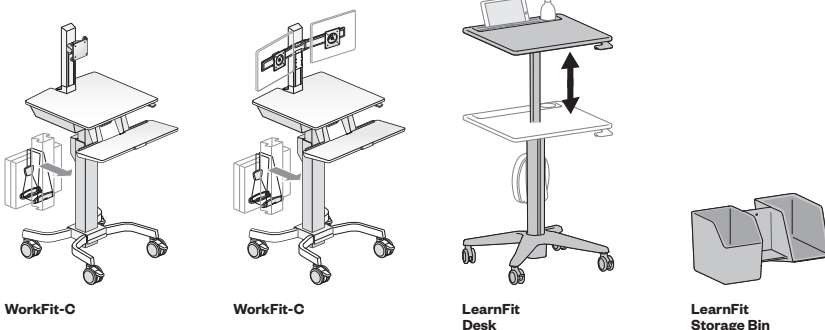

WorkFit-C

WorkFit-C

LearnFit
Desk

LearnFit
Storage Bin

Statement of Line

Ergotron Laptop Cart

Page 41

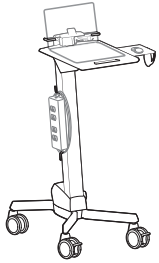

Neo-Flex

Ergotron Mobile Digital Workspace

Page 42



Teachwell®

Ergotron Keyboard Tray

Page 43



Keyboard Tray with Mouse Pad

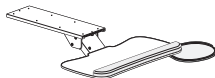

Keyboard Tray with Mouse Pad

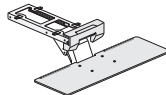

Neo-Flex Keyboard Tray

Ergotron CPU Holder

Page 44

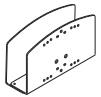

Small CPU Holder

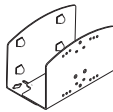

Universal CPU Holder



Cable CPU Holder

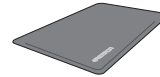

Anti-Fatigue Floor Mat

Lighting

Pages 45-49

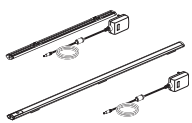

Adaptable LED Task Light Stand-Alone

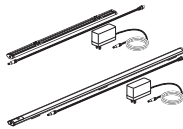

Adaptable LED Task Light Starter Kit



Adaptable LED Task Light Add-On Kit

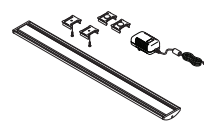

Reed Premier™ Stand-Alone LED Task Light

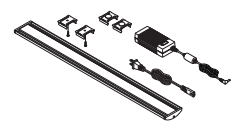

Reed Premier™ Starter LED Task Light



Reed Premier™ Task Light Add-On Kit

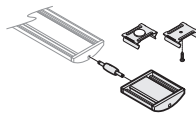

Reed Premier™ Add-On Occupancy Sensor

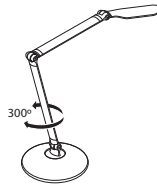

Voyage™ Without Occupancy Sensor

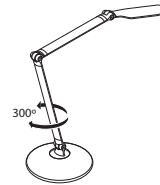

Voyage™ With Occupancy Sensor

Statement of Line

Storage – Suspended

Pages 50-51

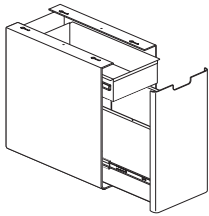

Belong
Suspended Pedestal

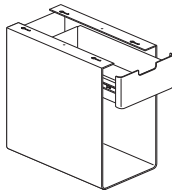

Belong
Suspended Pedestal

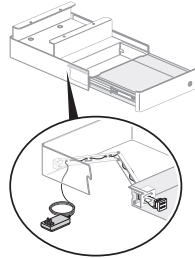

Belong
Security Drawer

Storage – Suspended Accessories

Page 52

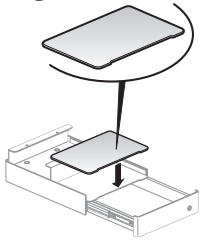

Belong
Top Liner
Security Drawer

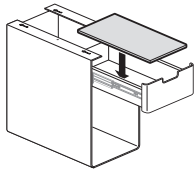

Belong
Drawer Liner

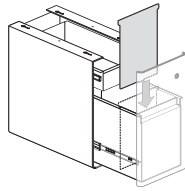

Belong
File Partition

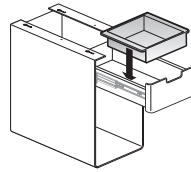

Belong
Drawer Tray

Storage Accessories

Pages 53-54

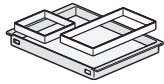

Belong
PDA Tray

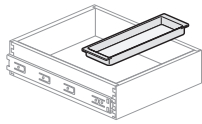

Belong
Personal Tray

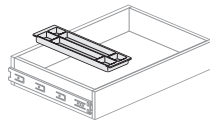

Belong
Pencil Tray

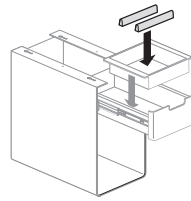

Belong
Magnetic Divider

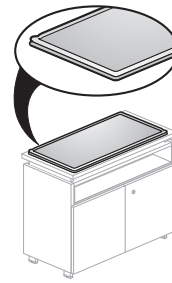

Belong
Cushion Top

Work Tools

Pages 55-70

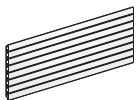

Rails and Mounting
Slat, Wall Mount

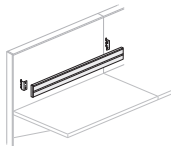

Rails and Mounting
Single Side

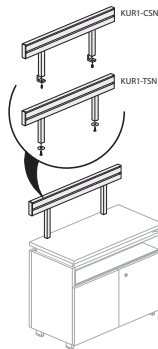

Rails and Mounting
Tool Rail
Horizontal Surface
Mount C-Clamp or
Thru-Mount

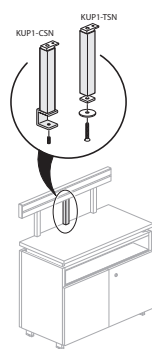

Rails and Mounting
Tool Rail
Single Post
C-Clamp or
Thru-mount

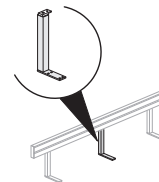

Rails and Mounting
Tool Rail
Single Post
L-Bracket Mount

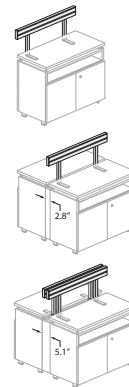

Rails and Mounting
Tool Rail
Under Horizontal Surface
Mount
L-Bracket

Statement of Line

Work Tools, (cont'd)

Pages 55-70

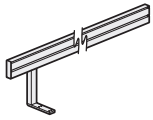

**Rails and Mounting
Tool Rail
Single Sided Continuous
Benching End**

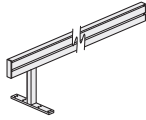

**Rails and Mounting
Tool Rail
Double-Sided Continuous
Benching End Application
Only**

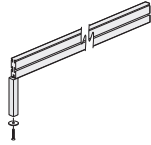

**Rails and Mounting
Tool Rail
Internal Single Sided
Continuous Benching
Application**

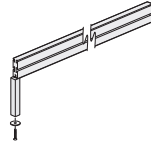

**Rails and Mounting
Tool Rail
Internal Continuous
Benching Application Only**

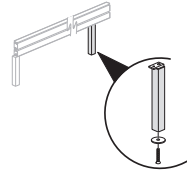

**Rails and Mounting
Tool Rail
Single Post
Internal/Benching**

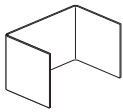

**Belong
Open C Cubby**

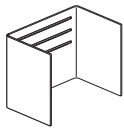

**Belong
Open C Cubby**



**Belong
Blotter**



**Belong
Small
Reference Shelf**

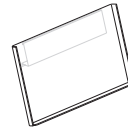

**Belong
Large
Reference Shelf**

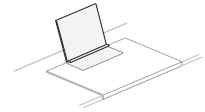

**Belong
Blotter
Reference Shelf**

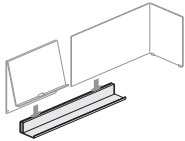

**Belong
Base Tray**

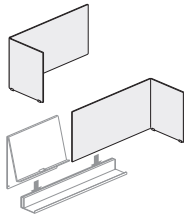

**Belong
Desk Top L-Screen**

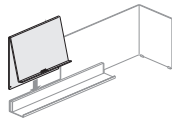

**Belong
Desk Top Reference Shelf**

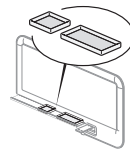

**Belong
Trays**

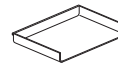

**Belong
Slat
Document Tray**

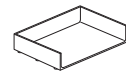

**Belong
Freestanding
Standing Tray**

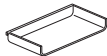

**Belong
Mini Shelf**

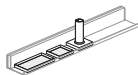

**Belong
Accessory Kit**



**Belong
Tool Cup**



**Belong
Hanging Sorter**

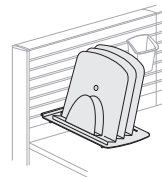

**Jump Stuff
Paper Sorter**

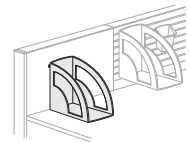

**Jump Stuff
Binder Bin**

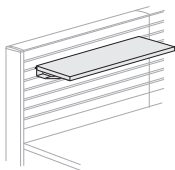

**Jump Stuff
Mini Shelf**

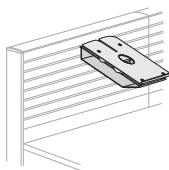

**Jump Stuff
Phone Shelf**

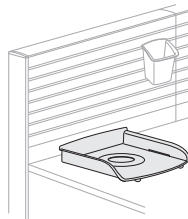

**Jump Stuff
Letter Tray**

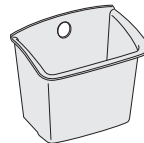

**Jump Stuff
Waste Bin**

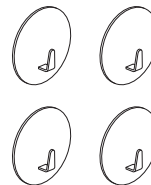

**Magnetic Accessories
Magnet Hooks**



**Magnetic Accessories
Magnet Hook**

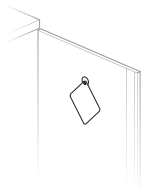

**Magnetic Accessories
Mirror**

Statement of Line

Workstation Accessories

Pages 71-75

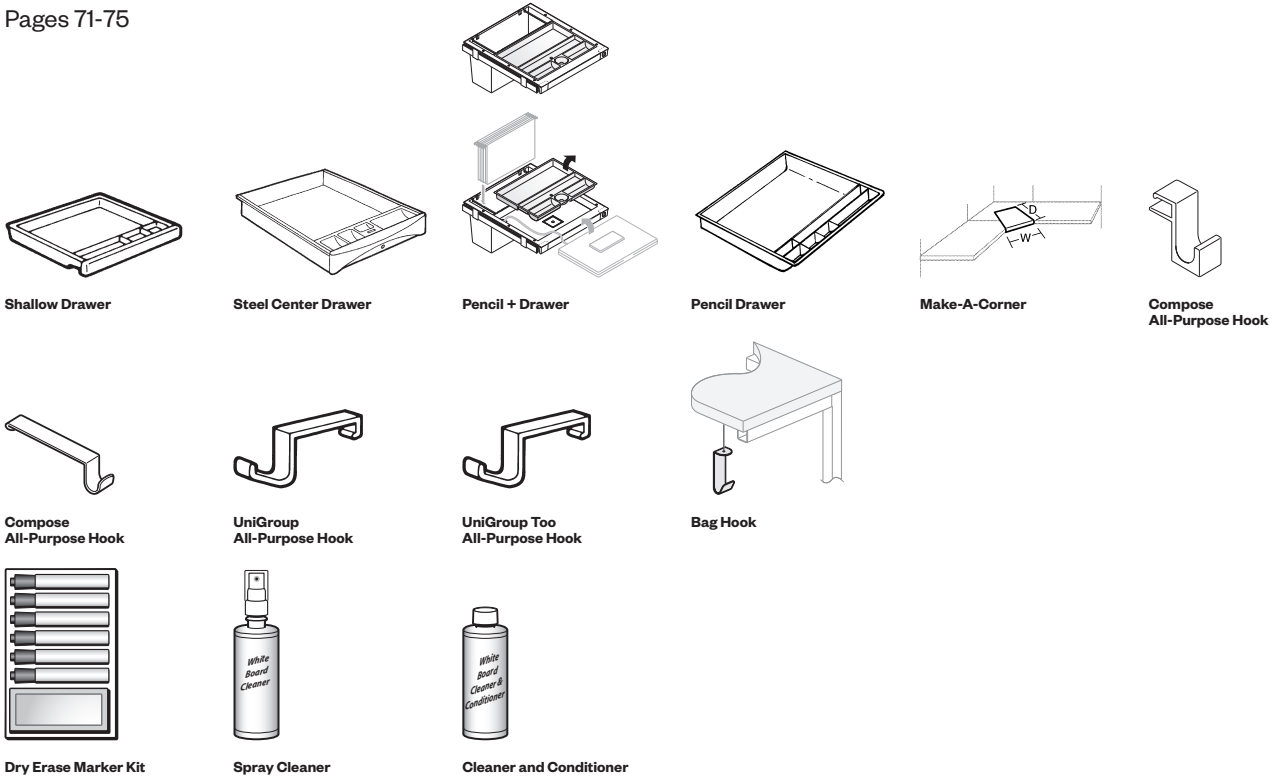

Waste Solutions

Page 76

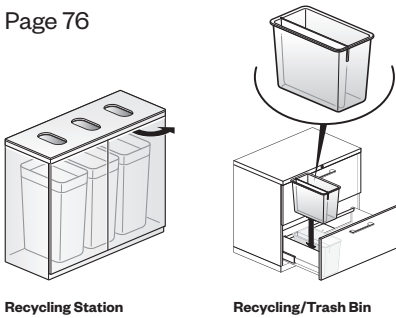

Lock Programs

Pages 80-82

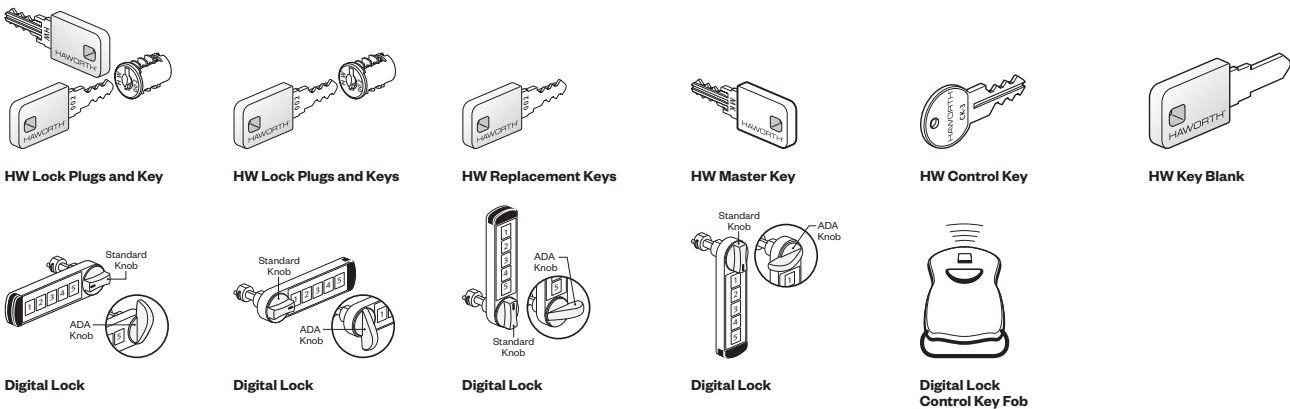

Belong Monitor Arm

Single

Single Monitor Arm

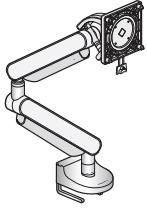

KUSM

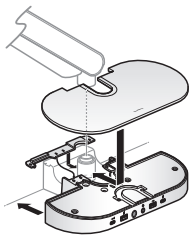

Techbase

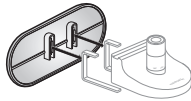

Wire Manager Cover
Class YAO

Features

- Includes upper and lower arm bodies, VESA plate, magnetic arm panels, integrated slide and snap cord management, single top down base clamp and hardware.
- For use with monitors up to 34"(864mm).
- Weight capacity 24.25 lbs.
- Height adjustment range is 11.42"(290mm).
- Tilts 35° up and 20° down.
- Monitor rotates 360°.
- Upper and lower arm each swivel 360° with 180° lockout.
- Extends monitors out 23.62"(600mm) from desk edge.
- Quick release VESA plate standard in supplier black.
- Top down mounting clamp for use on surfaces 0.63"(16mm)-1.3"(33mm) thick.
- Hide a key (allen wrench) integrated into arm/magnetic cover panels.

Specification Tips

- Monitor arms intended to support VESA compliant monitors.
- Techbase:
 - Included when base option (T) is specified.
 - Slides over clamp or grommet base.
 - Features 150 watts with multiple charging options.
 - Refer to product number KUTI-0000 for details.
- Wire Manager Cover:
 - Included when Wire Manager Cover option (Y) is specified.
 - Attaches magnetically to the clamp base.
 - Not for use with Grommet mount.
 - Recommended for open applications without privacy elements to conceal visible cords.
 - Refer to product number KURC-0000-P for additional details.
- Clamp base not for use on knife edge.
- Grommet mount available (KUSM-GROM). Not compatible with Wire Manager Cover.
- Can be used with Single Handle Kit (KUHk-0000-S).
- Can be used with VESA Slider Kit (KUVK-0000-S). Slider Kit accommodates monitors up to 38"(965mm)
- Single Handle Kit and VESA Slider Kit cannot be used together.
- Not for use with Planes training tables.
- Arm assembly and clamp base weigh 7.7 lbs.

To Order, Specify:

1) Product number, including:

1 Base Option:

- S Standard Base
- T Techbase (add **\$1019.00** list)

2 Wire Manager Cover Option:

- N No cover
- Y Cover (add **\$140.00** list)

2) Trim color:

- TR-K Charcoal
- TR-FM Snow

Number	12	Price
KUSM-0000-DS	<input type="checkbox"/> <input type="checkbox"/> Y	\$555.00

Belong Monitor Arm

Single with Crossbar

Single Monitor Arm with Crossbar

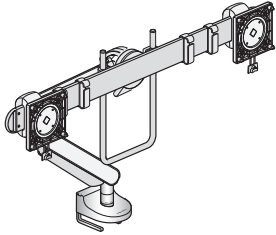

KUXM

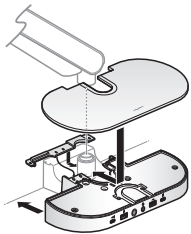

Techbase

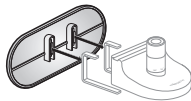

Wire Manager Cover
Class YAO

Features

- Includes upper and lower arm bodies, VESA plate, crossbar and handle, magnetic arm panels, integrated slide and snap cord management, handle kit, single top down base clamp and hardware.
- Supports two monitors 17"(432mm)-27"(686mm) each.
- Weight capacity of 10 lbs. per monitor.
- Height adjustment range is 11.42"(290mm).
- Tilts 20° up and 20° down.
- Monitors rotate 90°.
- Monitors individually pan 12° inward and outward.
- Upper and lower arm each swivel 360° with 180° lockout.
- Extends monitors out 23.62"(600mm) from desk edge.
- Quick release VESA plate standard in supplier black.
- Crossbar and its components standard in supplier black. Handle color will match specified arm color.
- Top down mounting clamp for use on surfaces 0.63"(16mm)-1.3"(33mm) thick.
- Hide a key (allen wrench) integrated into arm/magnetic cover panels.

Specification Tips

- Monitor arms intended to support VESA compliant monitors.
- Techbase:
 - Included when base option (T) is specified.
 - Slides over clamp or grommet base.
 - Features 150 watts with multiple charging options.
 - Refer to product number KUTI-0000 for details.
- Wire Manager Cover:
 - Included when Wire Manager Cover option (Y) is specified.
 - Attaches magnetically to the clamp base.
 - Not for use with Grommet mount.
 - Recommended for open applications without privacy elements to conceal visible cords.
 - Refer to product number KURC-0000-P for additional details.
- Clamp base not for use on knife edge.
- Grommet mount available (KUSM-GROM). Not compatible with Wire Manager Cover.
- Cannot be combined with VESA Slider Kit or Single Handle Kit.
- Recommend using two monitors of same size and weight.
- Not for use with Planes training tables.
- Arm assembly and clamp base, crossbar and handle weighs 11.59 lbs.

To Order, Specify:

1) Product number, including:

1 Base Type:

- S** Standard Base
- T** Techbase (add **\$1019.00** list)

2 Wire Manager Cover

- N** No cover
- Y** Cover (add **\$140.00** list)

2) Trim color:

- TR-K Charcoal
- TR-FM Snow

Number	1 2	Price
KUXM-0000-DS	■ ■ Y	\$875.00

Belong Monitor Arm

Dual

Dual Monitor Arm

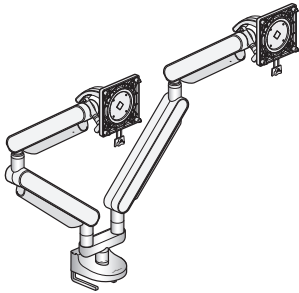

KUDM

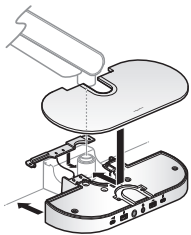

Techbase

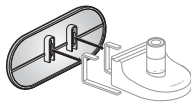

Wire Manager Cover
Class YAO

Features

- Includes two upper and two lower arm bodies, VESA plates, magnetic arm panels, integrated slide and snap cord management, single top down base clamp and hardware.
- For use with monitors up to 34"(864mm).
- Weight capacity of 24.25 lbs. per arm for total weight capacity of 48.5 lbs.
- Height adjustment range is 11.42"(290mm).
- Tilts 35° up and 20° down.
- Monitor rotates 360°.
- Upper and lower arm each swivel 360° with 180° lockout.
- Extends monitors out 23.62"(600mm) from desk edge.
- Quick release VESA plate standard in supplier black.
- Top down mounting clamp for use on surfaces 0.63"(16mm)-1.3"(33mm) thick.
- Hide a key (allen wrench) integrated into arm/magnetic cover panels.

Specification Tips

- Monitor arms intended to support VESA compliant monitors.
- Techbase:
 - Included when base option (T) is specified.
 - Slides over clamp or grommet base.
 - Features 150 watts with multiple charging options.
 - Refer to product number KUTI-0000 for details.
- Wire Manager Cover:
 - Included when Wire Manager Cover option (Y) is specified.
 - Attaches magnetically to the clamp base.
 - Not for use with Grommet mount.
 - Recommended for open applications without privacy elements to conceal visible cords.
 - Refer to product number KURC-0000-P for additional details.
- Clamp base not for use on knife edge.
- Grommet mount available (KUSM-GROM). Not compatible with Wire Manager Cover.
- Each arm can be used with Single Handle Kit (KUHk-0000-S).
- Each arm can be used with VESA Slider Kit (KUVK-0000-S). Slider Kit accommodates monitors up to 38"(965mm).
- Single Handle Kit and VESA Slider Kit cannot be used together.
- Not for use with Planes training tables.
- Recommend using two monitors of same size and weight.
- Dual arm assembly and clamp base weigh 15.2 lbs.

To Order, Specify:

1) Product number, including:

1 Base Type

- S Standard Base
- T Techbase (add **\$1019.00** list)

2 Wire Manager Cover

- N No cover
- Y Cover (add **\$140.00** list)

2) Trim color:

- TR-K Charcoal
- TR-FM Snow

Number	1 2	Price
KUDM-0000-DS	<input type="checkbox"/> <input type="checkbox"/> Y	\$1010.00

Belong Monitor Arm

Accessories

Belong Techbase

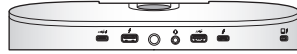
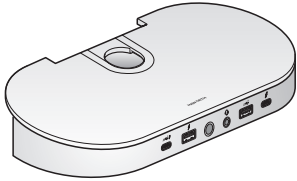

Front View

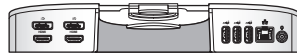

Back View

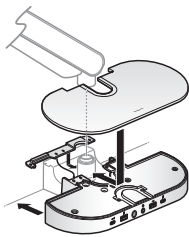

KUTI
Class YA0

Features

- Includes one technology base, charging adapter with plug and 5'11" cord, and 3'3" long USB-C cord.
- Base has 150W overall unit wattage and consists of the following:
 - Power on/off button with halo light when on
 - 1 USB-A QC 3.0 charging port (18W Max)
 - 1 USB-A 3.1 max 10 Gbps 5V, 0.9A port
 - 1 USB-C DFP charging port (20W Max)
 - 2 HDMI 2.0 ports
 - 2 Display 1.4 ports
 - 1 Ethernet port RJ45 2.5gb
 - 1 Combination jack (3.5mm standard-audio & mic)
 - 1 Thunderbolt® 4 DFP TBT4 Downstream (15W Max)
 - 1 Thunderbolt® 4 UFP (to host) Max 40 Gbps (65W-96W charging)
 - 1 Kensington lock

Specification Tips

- Must be mounted on a Belong Monitor Arm clamp or grommet base. Cannot be freestanding.
- Slides snugly over existing monitor arm base and snaps in place.
- Optional Wire Manager Cover (included when specified) is for use with clamp base only.
- Unit weight is 2.2 lbs.

Height	Depth	Width	Number ①	Price
1.71"(43mm)	5.01"(127mm)	10.26"(261mm)	KUTI-0000- <input type="checkbox"/> Y	\$1019.00

*Thunderbolt and Thunderbolt logo are trademarks of Intel Corporation or its subsidiaries.

To Order, Specify:

- 1) Product number, including:
 - ① Wire Manager Cover**
 - N No cover
 - Y Cover (add **\$140.00** list)
- 2) Trim color.
 - TR-K Charcoal
 - TR-FM Snow

Wire Manager Cover

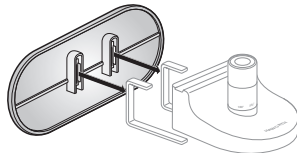

KURC
Class YA0

Features

- Includes one plastic wire manager cover.
- Pressure fit, magnetic mount wire manager cover mounts to Belong Monitor Arm clamp base only.
- Cover thickness is 0.173"(4mm) and has 2.5"(64mm) radius corners.

Specification Tips

- Only for use with Belong Monitor Arm standard base clamp.
- Recommended for open applications without privacy elements to conceal visible cords.
- Not for use in applications with desk or table privacy elements.

Height	Depth	Width	Number	Price
5"(127mm)	0.66"(17mm)	11"(279mm)	KURC-0000-P	\$140.00

To Order, Specify:

- 1) Product number.
- 2) Trim color.
 - TR-K Charcoal
 - TR-FM Snow

Grommet Mount Base

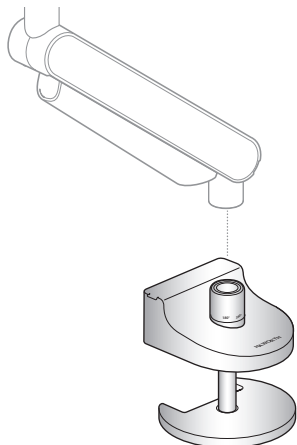

KUSM-GROM
Class YA0

Features

- Includes one grommet base.
- For use on work surfaces 0.393"(10mm) - 2.56"(65mm) thick.

Specification Tips

- Not compatible with Wire Manager Cover.
- Recommended hole size 1.5"(38mm)

Number	Price
KUSM-GROM	\$170.00

To Order, Specify:

- 1) Product number.
- 2) Trim color.
 - TR-K Charcoal
 - TR-FM Snow

Belong Monitor Arm

Accessories

Crossbar & Handle Kit

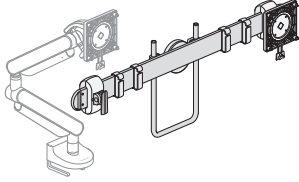

KUCK
Class YAO

Features

- Includes one VESA plate, crossbar with quick release bracket, handle and mounting hardware.
- Crossbar and VESA plate available in supplier black only.
- Handle available in TR-K Charcoal or TR-FM Snow.
- Accommodates up to two 27"(686mm) monitors.
- Weight capacity of 10 lbs. per monitor.

Specification Tips

- Kit intended to support VESA compliant monitors.
- Converts a single arm to a single arm with crossbar for two monitors locked together.
- Converts dual independent arms to a triple monitor configuration; one independent arm with crossbar locking two monitors together and one independent arm with single monitor.
- When utilizing for triple monitor applications, separately specified VESA Slider Kit is recommended for monitor adjustment on independent arm.
- Recommend using monitors of same size and weight.

To Order, Specify:

- 1) Product number.
- 2) Handle color.
TR-K Charcoal
TR-FM Snow

Number	Price
KUCK-0000-SY	\$419.00

Single Handle Kit

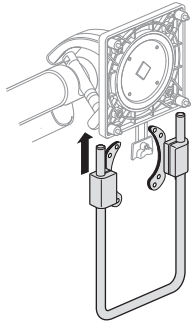

KUHK
Class YAO

Features

- Includes handle and mounting hardware.
- Mounts to VESA plate.

Specification Tips

- Kit intended to support VESA compliant monitors.
- For use with Belong Single Monitor Arm or Belong Dual Monitor Arm; one single handle per arm.
- Not for use with:
 - VESA Slider Kit
 - Crossbar & Handle Kit assembly.
- With handle attached to monitor and counterbalance adjusted as noted below, monitors operate with less than 5 lbs. of force for most users and applications. Please see installation video for counterbalance adjustment.

Monitor Weight	Counterbalance Adjustment
6.6 lbs.	1
8.89 lbs.	1.5
11.0 lbs	1.75

To Order, Specify:

- 1) Product number.
- 2) Trim color.
TR-K Charcoal
TR-FM Snow

Number	Price
KUHK-0000-S	\$195.00

VESA Slider Kit

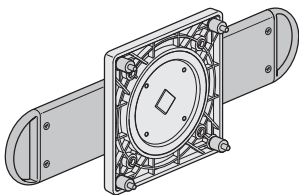

KUVK
Class YAO

Features

- Includes one slider, VESA plate and mounting hardware.
- Supplier black only.
- Allows monitor to slightly adjust along the slider

Specification Tips

- Kit intended to support VESA compliant monitors.
- For use with Belong Single Monitor Arm or Belong Dual Monitor arm; one slider kit per arm.
- Not for use with:
 - Crossbar and Handle Kit
 - Single Handle Kit
- Slider kit recommended to support monitor sizes up to 38"(965mm).

To Order, Specify:

- 1) Product number.

Number	Price
KUVK-0000-S	\$185.00

Belong Monitor Arm

Accessories

Single to Dual Conversion Kit

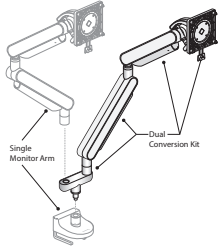

KUDK
Class YAO

Features

- Includes dual arm base adapter, single arm upper and lower bodies, two wire managers, VESA plate and four magnetic panels.
- Converts existing single monitor arm and base to a dual independent monitor arm configuration (additional base not needed).
- For use with monitors up to 34"(864mm).
- Weight capacity 24.25 lbs. per arm.

Specification Tips

- Monitor arms intended to support VESA compliant monitors.
- Each independent arm may be used with one of the following:
 - Single Handle Kit (KUHk-0000-S)
 - VESA Slider Kit (KUVK-0000-S). Slider kit increases maximum monitor size to 38"(965mm)
- Single Handle Kit and VESA Slider Kit cannot be used together.

To Order, Specify:

- 1) Product number.
- 2) Trim color.
TR-K Charcoal
TR-FM Snow

Number

KUDK-0000-SY

Price

\$545.00

Triple Conversion Kit

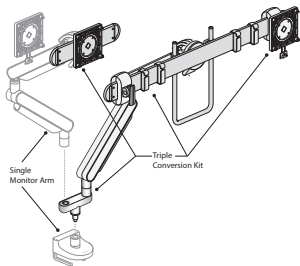

KUTK
Class YAO

- Includes dual arm base adapter, single arm upper and lower bodies, crossbar with handle, two wire managers, one VESA Slider Kit and four magnetic panels.
- Converts existing single monitor arm and base to a triple monitor configuration (additional base not needed).
- Weight capacity for independent arm is 24.25 lbs. Weight capacity of crossbar is 20 lbs.

Specification Tips

- Monitor arms intended to support VESA compliant monitors.
- Monitors of same size and weight recommended.
- Independent arm may be used with VESA Slider Kit **or** Single Handle Kit.
- VESA Slider Kit cannot be combined with Single Handle Kit.

To Order, Specify:

- 1) Product number.
- 2) Trim color.
TR-K Charcoal
TR-FM Snow

Number

KUTK-0000-SY

Price

\$1170.00

Ergotron Monitor Arms

MX

Desk Mount - Single Arm

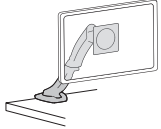

45-214-026
Class ER – GSA: Open Market

Features

- Includes: Adjustable height monitor arm, desk clamp and grommet mount.
- For use with screen 30"(762mm) or smaller.
- Accommodates monitors from 14-30 pounds.
- Height adjustment range is 5"(127mm).
- Tilts 75° up and 5° down from center.
- Rotates 90°.
- Pans 360°.
- Extends LCD's out up to 17"(432mm).
- Integrated cable management.
- One touch adjustment.

Specification Tips

- Desk clamp mounts on worksurface 0.4"(10mm) - 2.5"(64mm) thick.
- Grommet mounts attach through surface holes 0.31"(8mm) - 2"(51mm)W and up to 3"(76mm) thick.

To Order, Specify:

- 1) Product number.

Description	Number	Price
Polished Aluminum	45-214-026	\$617.41

Wall Mount - Heavy Duty

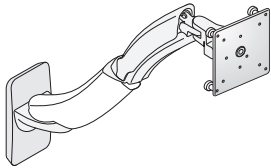

45-228-026
Class ER – GSA: Open Market

Features

- Includes: Arm with VESA adapter brackets, wall mount base and attachment hardware.
- For use with screen up to 42"(1067mm).
- Maximum weight capacity: 30 pounds.
- Height adjustment range is 5"(127mm).
- Tilts 75° up and 5° down.
- Rotates 90° and includes position lock.
- Pans 360°.
- Integrated cable management.
- One touch adjustment.

Specification Tips

- Recommended installation height:
Upper mounting hole of base should be placed no higher than 60"(1524mm) above floor.

To Order, Specify:

- 1) Product number.

Description	Number	Price
Polished Aluminum	45-228-026	\$662.63

Ergotron Monitor Arms

MXV Desk Mount

Single Arm

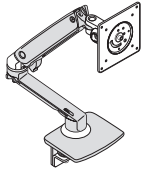

45-486

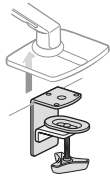

Two-Piece Clamp
Class ER - GSA: Open Market

Features

- Includes: Fully assembled slim profile arm, two-piece desk clamp or low-profile C-clamp, and mounting hardware.
- For use with screen 34"(864mm) or smaller.
- Accommodates monitors from 7-20 pounds.
- Height adjustment range is 13"(330mm).
- Tilts 90° backward and 90° forward.
- Rotates 360°.
- Pans 180° at base; 360° between extension and arm. Rotation stop on base can be disengaged at time of installation to increase range to a full 360°.
- Extends LCD monitor out 22.2"(559mm).
- Arm folds back over base into a compact retracted position; perfect for tucking under systems furniture storage shelves or cabinets in space constrained areas.
- Integrated cord management.
- One touch adjustment.

Specification Tips

- Two-Piece clamp mounts on worksurface 0.47"(12mm) - 1.25"(25mm) thick.
- Low profile top mount C-Clamp mounts on worksurfaces 0.98"(25mm) - 1.38"(35mm) thick.
- Desk clamp has anti-rotation screws to prevent base from slipping.
- Grommet mount available; separately specified part 98-110.

To Order, Specify:

- 1) Product number.

Description	Number	Price
Single Arm — Two-Piece Clamp		
Polished Aluminum	45-486-026	\$637.91
White	45-486-216	637.91
Matte Black	45-486-224	637.91

Dual Arm

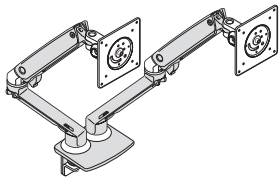

45-496

Class ER - GSA: Open Market

Features

- Includes: Fully assembled slim profile dual arm, two-piece desk clamp, and mounting hardware.
- For use with screen 24"(610mm) or smaller. Screen size may affect adjustment capability.
- Accommodates monitors from 7-20 pounds.
- Height adjustment range is 13"(330mm).
- Tilts 90° backward and 90° forward.
- Rotates 360°.
- Pans 180° at base; 360° between extension and arm. Rotation stop on base can be disengaged at time of installation to increase range to a full 360°.
- Extends LCD monitor out 22.2"(559mm).
- Arm folds back over base into a compact retracted position; perfect for tucking under systems furniture storage shelves or cabinets in space constrained areas.
- Integrated cord management.
- One touch adjustment.

Specification Tips

- Desk clamp mounts on worksurface 0.47"(12mm) - 1.25"(25mm) thick.
- Desk clamp has anti-rotation screws to prevent base from slipping.
- Grommet mount available; separately specified part 98-111.

To Order, Specify:

- 1) Product number.

Description	Number	Price
Polished Aluminum	45-496-026	\$1040.16
White	45-496-216	1040.18
Matte Black	45-496-224	1040.18

Ergotron Monitor Arms

MXV Accessories

Grommet Mount for MXV Single Monitor Arm

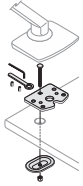

98-110
Class ER - GSA: Open Market

Feature

- Includes: Grommet plate and attachment hardware.

Specification Tips

- Compatible with MXV Single Monitor Arm.
- Mounts through surface .31"(8mm) - 1.25"(32mm)W and less than or equal to 1.3"(33mm) thick.

To Order, Specify:

- 1) Product number.

Number	Price
98-110	\$41.83

Grommet Mount for MXV Dual Monitor Arm



98-111
Class ER - GSA: Open Market

Feature

- Includes: Grommet plate and attachment hardware.

Specification Tips

- Compatible with MXV Dual Monitor Arm.
- Mounts through surface .31"(8mm) - 1.25"(32mm)W and less than or equal to 1.3"(33mm) thick.

To Order, Specify:

- 1) Product number.

Number	Price
98-111	\$57.79

Ergotron Monitor Arms

HX Desk Mount

Single Arm

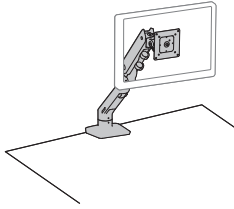

45-475
45-478
Class ER - GSA: Open Market

Features

- Includes: Adjustable height monitor arm, extension, monitor pivot, mounting hardware.
 - Desk mount includes desk clamp and grommet mount.
 - Wall mount includes mounting hardware.
- For use with screen 49"(1245mm) or smaller.
- Weight capacity 20-42 pounds.
- Height adjustment range is 11.5"(292mm).
- Tilts 70° up and 5° down from center.
- 180° rotation base stop.
- Pans 180°.
- Rotates 360°.
- Extends out up to 25"(635mm).
- Integrated cable management.
- One touch adjustment.

Specification Tips

- Desk clamp mounts on worksurface 0.4"(10mm) - 2.5"(64mm) thick.
- Grommet mount attaches through surface holes 0.4"(10mm) - 2"(51mm)W and up to 2.25"(57mm) thick.

To Order, Specify:

- 1) Product number.

Description	Number	Price
Desk Mount		
Polished Aluminum	45-475-026	\$959.40
White	45-475-216	959.40
Matte Black	45-475-224	959.40
Wall Mount		
Polished Aluminum	45-478-026	\$973.20

Dual Arm

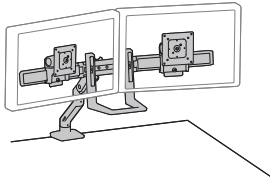

45-476
Class ER - GSA: Open Market

Features

- Includes: Adjustable height monitor arm, extension, two monitor pivots, hinged bow, handle, mounting hardware, desk clamp and grommet mount.
- For use with screen 32"(813mm) or smaller.
- Weight capacity is 5-17.5 pounds per screen. Maximum combined weight is 35 pounds.
- Height adjustment range is 11.5"(292mm).
- Tilts 70° up and 5° down from center.
- 180° rotation base stop.
- Pans 180° - Hinged bow allows monitors to pan from left to right independently.
- Rotates 360°.
- Extends out up to 24"(610mm).
- Quick release monitor.
- Integrated cable management.
- One touch adjustment.
- Handle allows for easy positioning of multiple monitors simultaneously.

Specification Tips

- Desk clamp mounts on worksurface 0.6"(15mm) - 2.5"(64mm) thick.
- Grommet mount attaches through surface holes 0.4"(10mm) - 2"(51mm)W and up to 2.25"(57mm) thick.

To Order, Specify:

- 1) Product number.

Description	Number	Price
Desk Mount		
Polished Aluminum	45-476-026	\$1561.91
White	45-476-216	1561.91
Matte Black	45-476-224	1561.91

Ergotron Monitor Arms

HX Accessories

Triple Monitor Blow Kit

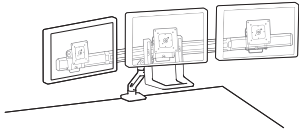
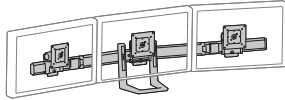

98-009-026
98-009-216

Class ER – GSA: Open Market

Features

- Includes: Triple monitor hinge bow, three monitor pivots, handle, monitor mounting hardware.
- For use with screen 24”(610mm) or smaller.
- Maximum weight capacity is 10.2 pounds per arm. Maximum combined weight is 30.6 pounds.
- Tilts 70° up and 5° down from center.
- Pans 180°.
- Rotates 360°.
- Extends out up to 24”(610mm).
- Quick release monitor.
- One touch adjustment.
- Handle allows for easy positioning of multiple monitors simultaneously.
- Attaches to HX single or dual monitor arm.

To Order, Specify:

- 1) Product number.

Description	Number	Price
Polished Aluminum	98-009-026	\$1025.50
White	98-009-216	1025.50

Ergotron Monitor Arms

Accessories

Dual Monitor and Handle Kit

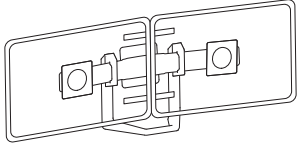

97-783
Class ER - GSA: Open Market

Features

- Includes: Monitor bow, two monitor pivots, handle and mounting hardware.
- For use with screens 26"(660mm) or smaller.
- Maximum weight capacity is 18 pounds per arm.
- Maximum combined weight is 36 pounds.
- Rotates 360°.
- Arm in polished aluminum, bow and handle in black.

Specification Tips

- This product adds an additional 6 pounds to your mounting solution. Monitor arm's maximum weight capacity must be reduced by 6 pounds.
- Attaches to mounts with four-hole interface of 50 x 50 mm or 100 x 100 mm.

To Order, Specify:

- 1) Product number.

Description	Number	Price
Polished Aluminum/Black	97-783	\$316.62

Monitor Quick Release LCD Bracket



60-589-060
Class ER - GSA: Open Market

Features

- Includes: Bracket, screws and stand-offs.
- For use with monitors less than 3"(76mm) thick.
- Bracket weighs 1.2 pounds and is 0.5"(13mm) thick. Weight of the bracket needs to be considered when determining weight capacity of the monitor arm.

To Order, Specify:

- 1) Product number.

Description	Number	Price
Black	60-589-060	\$67.91

Top Mount Low Profile C-Clamp

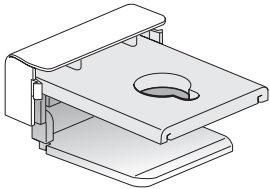

98-478
Class ER - GSA: Open Market

Feature

- Includes: One C-clamp and mounting hardware.

Specification Tips

- For use when installing current low-profile C-clamp monitor arm onto a different surface thickness.
- Cannot be used to retrofit monitor arms originally fitted with 2-piece clamps or grommet mounts.
- Compatible with LX Single and Dual Monitor Arms and MXV Monitor Arm.
- Requires open space of 0.8"(20mm) behind surface for installation.
- For use on surfaces 0.71"(18mm) - 0.98"(25mm) thick.

To Order, Specify:

- 1) Product number.

Description	Number	Price
Matte Black	98-478-224	\$117.09

Ergotron Monitor Mount

TRACE

Single Monitor

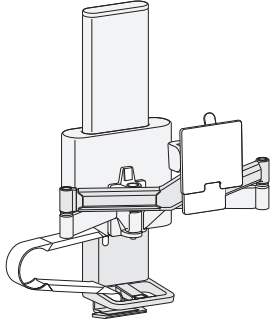

TDS-MA-PA-251

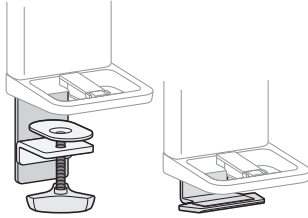

Panel Clamp
TDS-MA-PA

Freestanding Clamp
TDS-MA-FS

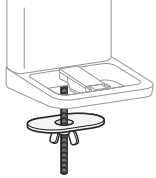

Grommet Mount
TDS-MA-GR

Class ER – GSA: Open Market

Features

- Includes lift column, extension arms, cable management channel, pivot, base, VESA spacer, mounting option and hardware.
- Mounting options include panel clamp, slim profile freestanding clamp or grommet mount.
- For use with screen up to 38" (965mm).
- Maximum weight capacity is 21.5 pounds.
- Height adjustment range is 11" (279mm).
- Tilts 75° up and 5° down.
- Rotates 360°.
- Pans 240°.
- Extension/retraction motion range is 15" (381mm).
- Integrated cable management.
- One touch adjustment.

Specification Tips

- Panel clamp attaches to surface edge up to 2.55" (65mm) thick.
- Slim profile clamp attaches to surface edge 0.47" (12mm) - 1.26" (32mm) thick.
- Grommet clamp attaches through surface hole 0.31" (8mm) - 2" (51mm)W and up to 2.56" (65mm) thick.

To Order, Specify:

- 1) Product number.

Description	Number	Price
Panel Clamp		
White	TDS-MA-PA-251	\$1254.96
Matte Black	TDS-MA-PA-224	1254.96
Slim Profile Freestanding Clamp		
White	TDS-MA-FS-251	\$1254.96
Matte Black	TDS-MA-FS-224	1254.96
Grommet Mount		
White	TDS-MA-GR-251	\$1254.96
Matte Black	TDS-MA-GR-224	1254.96

Ergotron Monitor Mount

TRACE

Dual Monitor

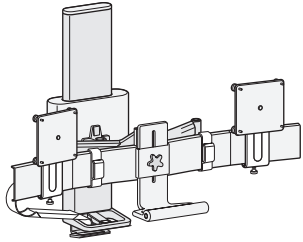

TDD-MA-PA

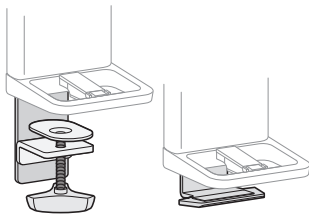

Panel Clamp
TDD-MA-PA

Freestanding Clamp
TDD-MA-FS



Grommet Mount
TDD-MA-GR

Class ER - GSA: Open Market

Features

- Includes lift column, extension arms, cable management channel, bow, two sliding pivots, base, VESA plates, mounting option and hardware.
- Mounting options include panel clamp, slim profile freestanding clamp or grommet mount.
- For use with screen up to 27" (686mm).
- Maximum weight capacity is 21.5 pounds total.
- Height adjustment range is 11" (279mm).
- Tilts 30° up and 5° down.
- Rotates 360°.
- Pans 240°.
- Extension/retraction motion range is 15" (381mm).
- Integrated cable management.
- One touch adjustment.

Specification Tips

- Panel clamp attaches to surface edge up to 2.55" (65mm) thick.
- Slim profile clamp attaches to surface edge 0.47" (12mm) - 1.26" (32mm) thick.
- Grommet clamp attaches through surface hole 0.31" (8mm) - 2" (51mm)W and up to 2.56" (65mm) thick.

To Order, Specify:

- 1) Product number.

Description	Number	Price
Panel Clamp		
White	TDD-MA-PA-251	\$1887.46
Matte Black	TDD-MA-PA-224	1887.46
Slim Profile Freestanding Clamp		
White	TDD-MA-FS-251	\$1887.46
Matte Black	TDD-MA-FS-224	1887.46
Grommet Mount		
White	TDD-MA-GR-251	\$1887.46
Matte Black	TDD-MA-GR-224	1887.46

Ergotron Monitor Mount

TRACE Accessories

Single Conversion Kit

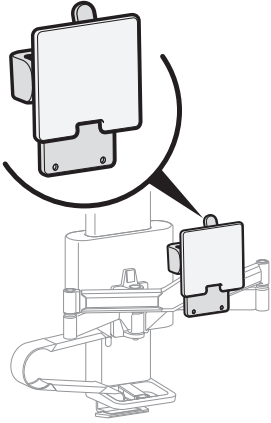

47-109-224
Class ER – GSA: Open Market

Features

- Includes tilting pivot and attachment hardware.
- Converts TRACE dual monitor mount configuration into a single monitor set-up.
- For use with screen up to 38”(965mm).
- Maximum weight capacity: 25.6 pounds.
- Tilts 75° up and 5° down.
- Rotates 360°.
- Pans 240°.

To Order, Specify:

- 1) Product number.

Description	Number	Price
Matte Black	47-109-224	\$331.63

Dual Conversion Kit

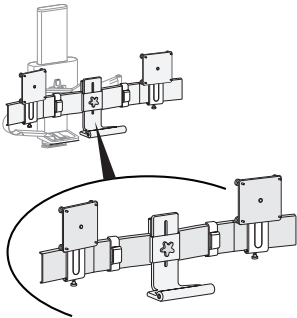

47-110-224
Class ER – GSA: Open Market

Features

- Includes bow, handle, two pivots and mounting hardware.
- Converts TRACE single monitor mount configuration into a dual monitor set-up.
- For use with screen up to 26”(660mm).
- Maximum weight capacity: 17.4 pounds. Maximum weight of 8.7 lbs per pivot.
- Tilts 30° up and 5° down.
- Rotates 360°.
- Pans 240°.

To Order, Specify:

- 1) Product number.

Description	Number	Price
Matte Black	47-110-224	\$657.49

Ergotron Sit-Stand Workstation WorkFit A

Dual Attached

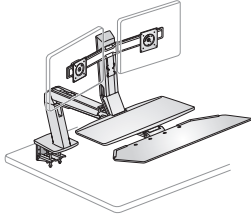

24-312-026

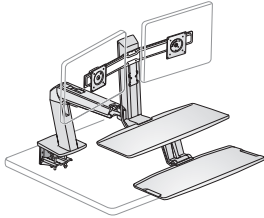

24-392-026

Class ER – GSA: Open Market

Features

- Includes: Arm, two LCD pivots, worksurface, crossbow, keyboard tray, desk clamp and hardware.
- For use with screen 24"(610mm) or smaller.
- Maximum weight capacity:
 - Total capacity 25 pounds
 - LCD - 4,5-10 pounds each.
 - Keyboard tray - 2 pounds
 - Worksurface - 5 pounds
- Keyboard tray dimension: 9.75"(248mm)D x 27"(686mm)W.
- In seated position, keyboard tray can drop down approximately 4"(102mm) below desktop surface.
- Worksurface dimension: 9.75"(248mm)D x 22.63"(575mm)W.
- Height adjustment range is 20"(508mm) with LCD and keyboard tray in tandem. LCD's adjust 5"(127mm) independently from worksurface. Maximum LCD height adjustment is 25"(635mm).
- Pans 180°.
- Rotates 360°.
- Integrated cable management.
- Black with polished aluminum extension and base.

Specification Tips

- Desk clamp mounts on worksurface up to 31.5"(800mm)D and 0.5"(13mm)-2.5"(64mm) thick.
- Minimum weight capacity of 12 pounds to ensure proper operation.
- Keyboard tray can be installed in three different positions: centered, offset right or offset left.

To Order, Specify:

- 1) Product number.

Description	Height	Depth	Width	Number	Price
With Worksurface	42.7"(1085mm)	16.9"(429mm)- 43.7"(1110mm)	27"(686mm)	24-316-026	\$1673.15
With Worksurface and Suspended Keyboard	38.8"(986mm)	16.9"(429mm)- 43.7"(1110mm)	27"(686mm)	24-392-026	1756.67

Ergotron Sit-Stand Workstation

WorkFit-S

Single Attached

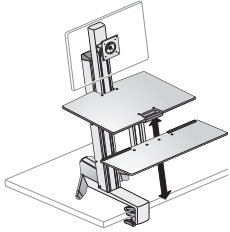

33-350-200
Class ER – GSA: Open Market

Features

- Includes: Height-adjustment column, desk clamp, LCD pivot, keyboard tray, and worksurface when applicable.
- Keyboard tray dimensions:
–With Worksurface - 9”(229mm)D x 27”(686mm)W.
- Worksurface dimensions: 15”(381mm)D x 23”(584mm)W.
- Height adjustment range is 18”(457mm) with LCD and keyboard tray in tandem. LCD’s adjust 5”(127mm) independently. Maximum LCD height adjustment is 23”(584mm).
- For use with screen 24”(610mm) or smaller.
- Maximum weight capacity:
–Total capacity is 24 pounds
–LCD - 6-16 pounds
–Keyboard - 5 pounds
–Worksurface - 5 pounds.
- Tilts 30°.
- Rotates 360°.
- Keyboard tray tilts back 5°.

To Order, Specify:

- 1) Product number.

Specification Tips

- Desk clamp mounts on front of worksurface 0.5”(13mm)-2.4”(61mm) thick.
- Height measured from desktop to lowest and highest positions.

Description	Height	Depth	Width	Number	Price
Black	29.4”(747mm)-35”(889mm)	16.3”(414mm)	27”(686mm)	33-350-200	\$1856.26

Dual Attached

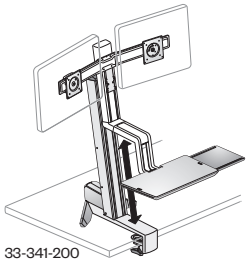

33-341-200

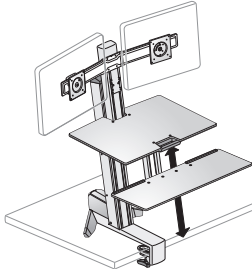

33-349-200
33-349-211
Class ER – GSA: Open Market

Features

- Includes: Height-adjustment column, desk clamp, crossbar, two LCD pivots, keyboard tray, and left/right mouse tray or worksurface when applicable.
- For use with screen 24”(610mm) or smaller.
- Maximum weight capacity:
–Total capacity 31 pounds.
–LCD - 6-14 pounds without worksurface. With worksurface LCD weight capacity 6-12 pounds.
–Keyboard tray - 5 pounds.
–Worksurface (when specified) - 5 pounds
- Keyboard tray dimensions:
–Without Worksurface - 9.3”(236mm)D x 16.5”(419mm)W.
–With Worksurface - 9”(229mm)D x 27”(686mm)W.
- Mouse tray available on without worksurface model only. May be installed on left or right side of keyboard tray. Dimensions: 7.9”(201mm)D x 7.5”(191mm)W.
- Worksurface dimensions: 15”(381mm)D x 23”(584mm)W.
- Height adjustment range is 18”(457mm) with LCD and keyboard tray in tandem. LCD’s adjust 5”(127mm) independently. Maximum LCD height adjustment is 23”(584mm).
- Rotates 90°.
- Keyboard tray tilts back 5°.

To Order, Specify:

- 1) Product number.

Specification Tips

- Desk clamp mounts on front of worksurface 0.5”(13mm)-2.4”(61mm) thick.
- Height measured from desktop to lowest and highest positions.

Description	Height	Depth	Width	Number	Price
Without Worksurface					
Black	29.4”(747mm)- 35”(889mm)	16.3”(414mm)	24”(610mm)	33-341-200	\$ 1513.23
With Worksurface					
Black	29.4”(747mm)- 35”(889mm)	16.3”(414mm)	27”(686mm)	33-349-200	\$1969.32
White	29.4”(747mm)- 35”(889mm)	16.3”(414mm)	27”(686mm)	33-349-211	1984.77

Ergotron Sit-Stand Workstation

WorkFit-T

Desktop

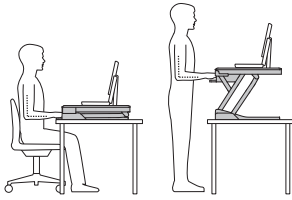
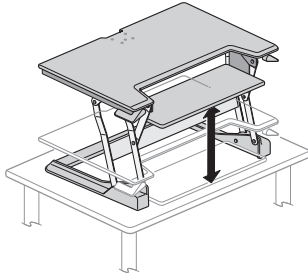

33-397-085
Class ER - GSA: Open Market

Features

- Includes: One height adjustable workstation with keyboard tray. For use with screen 30"(762mm) or smaller. Maximum weight capacity: 10-35 pounds.
- Keyboard tray dimensions are 25"(635mm)W x 9"(229mm)D.
- Total height adjustment range is 15"(381mm). Monitor and keyboard move in tandem.
- Keyboard tray sits 14.5"(368mm) below WorkFit worksurface.
- Ships fully assembled.

Specification Tips

- Fits on surfaces 24"(610mm)D or larger including corner surfaces.
- Monitor can be placed directly on the worksurface or monitor mount can be used; sold separately.

To Order, Specify:

- 1) Product number.

Description	Depth	Width	Number	Price
Black	25"(635mm)	35"(889mm)	33-397-085	\$1332.30

Ergotron Sit-Stand Workstation

WorkFit-TL

Desktop

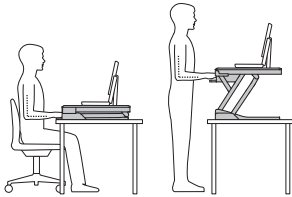
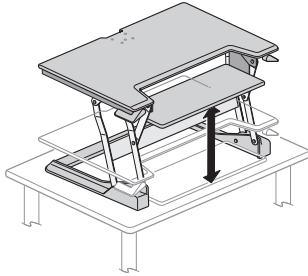

33-406-085
 33-418-085
 Class ER - GSA: Open Market

Features

- Includes: One height adjustable workstation with keyboard tray.
- TAA compliant version assembled in the USA in black only.
- For use with screen 30"(762mm) or smaller.
- Maximum weight capacity: 10-40 pounds.
- Keyboard tray dimensions are 27.5"(699mm)W x 11"(279mm)D.
- Total height adjustment range is 15"(381mm). Monitor and keyboard move in tandem.
- Keyboard tray sits 4.5"(114mm) below WorkFit worksurface.
- Ships fully assembled.

Specification Tips

- Fits on desks 24"(610mm)D or larger.
- Monitor can be placed directly on the worksurface or monitor mount can be used; sold separately.

To Order, Specify:

- 1) Product number.

Description	Depth	Width	Number	Price
Black	27"(686mm)	37.5"(953mm)	33-406-085	\$1449.10
Black - TAA Compliant	27"(686mm)	37.5"(953mm)	33-418-085	2436.61

Ergotron Sit-Stand Workstation

WorkFit-Z Mini

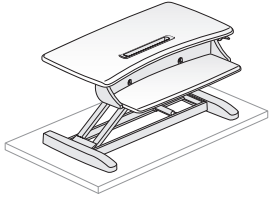

33-458-917
Class ER - GSA: Open Market

Features

- Includes: Desk converter with device slot and keyboard tray, leg covers, and cable ties.
- For use with screen 24"(610mm) or smaller.
- Maximum weight capacity: 25 pounds.
- Offers 12.5"(318mm) of click-free/noise free vertical lift. Maximum height 17.9"(455mm).
- Keyboard tray is 4.3"(109mm) below worksurface and moves in tandem with the worksurface.
- Dimensions:
Worksurface: 15.8"(401mm)D X 31"(787mm)W
Keyboard Tray: 9.1"(231mm)D X 24.5"(622mm)W
Device Slot: 1.1"(28mm)D X 11"(279mm)W
- Unit weighs 34.3 pounds.
- Standard with dove grey woodgrain surface and black frame.

Specification Tips

- Fits on desk surfaces 22"(559mm)D or larger.
- Routes cables and cords with through-holes at bottom of device slot and behind keyboard tray.

To Order, Specify:

- 1) Product number.

Description	Height	Depth	Width	Number	Price
Grey Woodgrain/Black	5.4"(137mm)-17.9"(455mm)	16.3"(414mm)	31"(787mm)	33-458-917	\$849.17

Ergotron Standing Workstation

WorkFit-TX

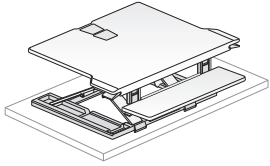

33-467-921
Class ER – GSA: Open Market

Features

- Includes: one height adjustable workstation with keyboard tray, cable management hardware and non-slip pads.
- For use with screen up to 30"(762mm).
- Maximum weight capacity: 40 pounds.
- Worksurface and keyboard tray adjust 17"(432mm) in tandem. Keyboard tray adjusts 3"(76mm) independently. Total adjustment range of 20"(508mm).
- Keyboard tray can be positioned as low as 3.5"(89mm) below worksurface.
- Dimensions:
Worksurface: 27"(686mm)D X 32"(813mm)W
Keyboard Tray: 8"(203mm)D X 28"(711mm)W
- Unit weighs 58.4 pounds.
- Standard in Black.

Specification Tips

- Fits on desk surfaces 24"(610mm)D or larger.
- Monitor can be placed directly on the worksurface or monitor mount can be used.
- Ships fully assembled.

To Order, Specify:

- 1) Product number.

Description	Height	Depth	Width	Number	Price
Black	19"(483mm)	27"(686mm)	32"(813mm)	33-467-921	\$2016.00

Ergotron Standing Workstation

WorkFit Corner

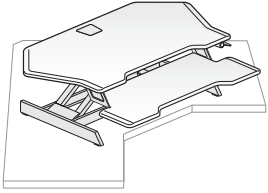

33-468-921
Class ER - GSA: Open Market

Features

- Includes: one height adjustable workstation with keyboard tray, cable management hardware and non-slip pads.
- For use with screen up to 30"(762mm).
- Maximum weight capacity: 35 pounds (worksurface up to 30 lbs; keyboard up to 5 lbs).
- Keyboard tray is positioned 4.5"(114mm) below worksurface.
- Worksurface and keyboard tray adjust 15"(381mm) in tandem.
- Dimensions:
Worksurface: 23.6"(599mm)D X 44"(1118mm)W
Keyboard Tray: 8.5"(216mm)D X 36"(914mm)W
- Unit weighs 59 pounds.
- Standard in Black.

Specification Tips

- Fits on desk surfaces 24"(610mm)D or larger.
- Monitor can be placed directly on the worksurface or monitor mount can be used.
- Ships fully assembled.

To Order, Specify:

- 1) Product number.

Description	Height	Depth	Width	Number	Price
Black	15"(381mm)	32"(813mm)	44"(1118mm)	33-468-921	\$1494.86

Ergotron Accessories

WorkFit-A / WorkFit-S

Conversion Kit: Dual to LCD & Laptop

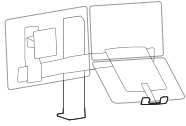

97-617
Class ER – GSA: Open Market

Features

- Includes: Laptop tray, riser bracket, monitor pivot and mounting hardware.
- Converts WorkFit-S or WorkFit-A Dual workstation into a WorkFit LCD and laptop workstation.
- For use with screens 24”(610mm) or smaller.
- Monitor tilts 30°.
- Pans 180°.
- Monitor rotates 360°.
- Weight capacity is contingent on the WorkFit platform to which the kit is added.

Specification Tips

- Compatible with WorkFit-A or WorkFit-S workstation.

To Order, Specify:

- 1) Product number.

Description	Number	Price
Black	97-617	\$238.27

Conversion Kit: LCD & Laptop to Dual

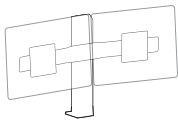

97-616
Class ER – GSA: Open Market

Features

- Includes: Two monitor pivots and mounting hardware.
- Converts WorkFit-S or WorkFit-A LCD & Laptop workstation into a Dual Workstation.
- For use with screens 22”(559mm) or smaller.
- Rotates 360°.
- Weight capacity is contingent on the WorkFit platform to which the kit is added.

To Order, Specify:

- 1) Product number.

Description	Number	Price
Black	97-616	\$140.28

Tall-User Kit for WorkFit Dual

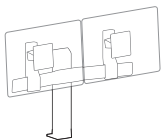

97-615
Class ER – GSA: Open Market

Features

- Includes: Two monitor pivots, two riser brackets and mounting hardware.
- Converts WorkFit-S or WorkFit-A Dual display workstation to improve ergonomic height requirements of taller users.
- For use with screens 24”(610mm) or smaller.
- Maximum weight capacity:
 - Total capacity 28 pounds.
 - LCD – 6-14 pounds.
- Rotates 360°.
- Adds 30° of up/down tilt to displays.
- Weight capacity is contingent on the WorkFit platform to which the kit is added.

To Order, Specify:

- 1) Product number.

Specification Tips

- Compatible with WorkFit-S and WorkFit-A. Also works with Dual Monitor Kit for WorkFit-T.

Description	Number	Price
Black	97-615	\$199.85

Ergotron Accessories

WorkFit-A / WorkFit-S

Corner Keyboard Tray

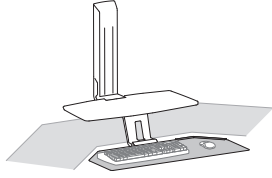

97-898
Class ER - GSA: Open Market

Features

- Includes: Corner single piece keyboard tray and mounting hardware.
- Maximum weight capacity is 5 pounds.

Specification Tips

- Compatible with WorkFit-S and WorkFit-A.
- Installs centered or offset to the right or left side.

To Order, Specify:

- 1) Product number.

Description	Height	Depth	Width	Number	Price
Black	.25"(6mm)	11"(279mm)	27"(686mm)	97-898	\$222.65

Grommet Mount

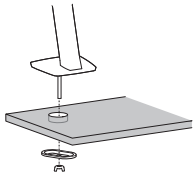

97-692
Class ER - GSA: Open Market

Features

- Includes one grommet mount.
- For use with WorkFit-A.
- Black pole and hardware with polished aluminum base.

Specification Tips

- Attaches through surface hole 0.5"(13mm) to 2.5"(64mm)W and up to 2.6"(66mm) thick.
- For maximum support, screw should be centered through hole.

To Order, Specify:

- 1) Product number.

Description	Number	Price
Polished Aluminum/Black	97-692	\$103.68

Dual Monitor Double-Hinged Bow

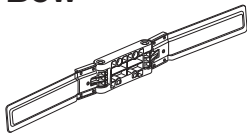

98-101-009
Class ER - GSA: Open Market

Features

- Includes: Double-hinged bow and mounting hardware.
- For use with screens 25"(635mm) or smaller.
- Weight capacity is 6-14 pounds each. Capacity may vary depending on WorkFit capacity.
- Pans 168° from front to back using monitors 18"(457mm) or smaller. Panning motion may be restricted when using screens 19"(483mm)-25"(635mm) in size.

Specification Tips

- Compatible with WorkFit-A, WorkFit-S, WorkFit-SR dual workstations.
- Pivots are not included. Use pivots from current workstation.

To Order, Specify:

- 1) Product number.

Description	Number	Price
Black	98-101-009	\$213.64

Ergotron Accessories

WorkFit-T/WorkFit-TL

WorkFit Single LCD Monitor Kit

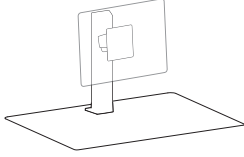

97-935
Class ER - GSA: Open Market

Features

- Includes: 5"(127mm) lift engine, one monitor pivot, dual bow, hardware, and cable management and ties.
- For use with screen 24"(610mm) or smaller.
- Maximum weight capacity: 6-16 pounds.
- Tilts 30°.
- Rotates 360°.

Specification Tips

- Compatible with WorkFit-T and WorkFit-TL, WorkFit-TLE, WorkFit-TX and WorkFit Corner.
- When added to a WorkFit workstation, overall capacity decreases by 6.6 pounds.

To Order, Specify:

- 1) Product number.

Description	Number	Price
Black	97-935-085	\$365.80

WorkFit Dual Monitor Kit

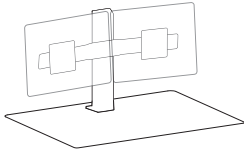

97-934
Class ER - GSA: Open Market

Features

- Includes: 5"(127mm) lift engine, two monitor pivots, dual bow, hardware, and cable management and ties.
- For use with screen 24"(610mm) or smaller.
- Maximum weight capacity:
 - Total weight 12-28 pounds.
 - LCD weight 6-14 pounds each.
- Rotates 360°.

Specification Tips

- Compatible with WorkFit-T and WorkFit-TL, WorkFit-TLE, WorkFit-TX and WorkFit Corner.
- When added to a WorkFit workstation, overall capacity decreases by 9.7 pounds.

To Order, Specify:

- 1) Product number.

Description	Number	Price
Black	97-934-085	\$524.84

Ergotron Mobile Cart WorkFit-C

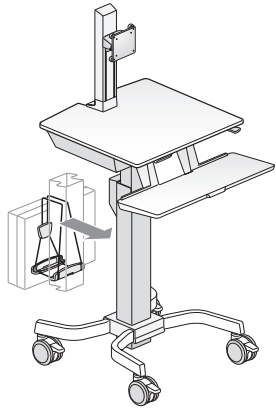

24-215-085
24-216-085

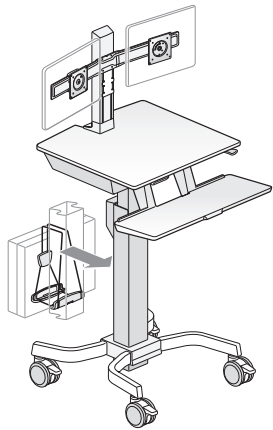

24-214-085
Class ER - GSA: Open Market

Features

- Includes cart, LCD mount(s), integrated worksurface, stowable keyboard tray, cable storage box, CPU holder, four dual casters (two locking), hand brake system and cable-winding bracket.
- Maximum screen size is 24"(610mm).
- Height adjustment range is 20"(508mm) with worksurface and keyboard tray in tandem. LCD adjusts 5"(127mm) independently; maximum LCD height adjustment 25"(635mm).
- Dimensions:
Worksurface: 23"(584mm)D x 24"(610mm)W
Keyboard tray: 9.4"(239mm)D x 26.3"(668mm)W
- Keyboard tray stows under worksurface.
- CPUs attach to rear of cart. Holder capacity 40 pounds.
- Tilt: LD and HD tilt 30°. Dual monitors do not tilt.
- Rotation: LD and Dual rotates 360° and HD rotates 90°.

To Order, Specify:

- 1) Product number.

Specification Tips

Description	Maximum Screen Size	Weight Capacity			
		Total	LCD	Keyboard Tray	Worksurface
LD	27"(686mm)	24.9 lbs.	16 lbs.	2 lbs.	5 lbs.
HD	30"(762mm)	32.5 lbs.	28 lbs.	2 lbs.	5 lbs.
Dual	24"(610mm)	32.5 lbs.	28 lbs.	2 lbs.	5 lbs.

Description	Height	Depth	Width	Number	Price
Single LD — Light Duty					
Black & Grey	14"(356mm)-19"(483mm)	23"(584mm)	26.3"(668mm)	24-215-085	\$2679.78
Single LD — Heavy Duty					
Black & Grey	14"(356mm)-19"(483mm)	23"(584mm)	26.3"(668mm)	24-216-085	\$2903.03
Dual Mount					
Black & Grey	14"(356mm)-19"(483mm)	23"(584mm)	26.3"(668mm)	24-214-085	\$3029.34

Ergotron Mobile Cart

LearnFit

LearnFit Desk

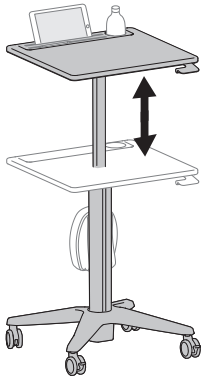

24-547-003
24-481-003
Class ER - GSA: Open Market

Features

- Includes: One adjustable height desk with two locking and 2 non-locking casters and backpack hook.
- PrecisionHeight™ Technology allows for one-touch height adjustment.
- Worksurface includes built in cup holder, tablet stand pocket and pencil tray.
- Maximum weight capacity for desk surface is 15 pounds.
- Sit-Stand desk height range is 29"(737mm)-45"(1143mm). Adjustable Standing desk height range is 33"(838mm)-49"(1245mm).
- Standard with polished aluminum column and base with feathered gray laminate surface. Edgeband and cup holder/pencil tray standard in dark gray.

To Order, Specify:

- 1) Product number.

Description	Height	Depth	Width	Number	Price
Sit-Stand	29"(737mm)-44"(1118mm)	22"(559mm)	24"(610mm)	24-547-003	\$1270.41
Standing	33"(838mm)-49"(1245mm)	22"(559mm)	24"(610mm)	24-481-003	1270.30

Storage Bin

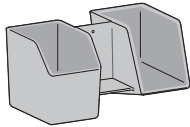

97-926-064
Class ER - GSA: Open Market

Features

- Includes: Molded plastic bins and mounting hardware.
- Sized to hold notebooks, folders and books.
- Smooth plastic surface.
- Maximum weight capacity is 8 pounds.
- Three separate compartments:
 - Enclosed, top-loaded on left side.
 - 3-sided, front-loaded on right side.
 - Smaller, 3-sided, front-loaded in center.

To Order, Specify:

- 1) Product number.

Specification Tips

- Compatible with LearnFit Adjustable Standing Desk
- Attaches at any height along the desk column.

Description	Height	Depth	Width	Number	Price
Dark Gray	8"(203mm)	8"(203mm)	14.5"(368mm)	97-926-064	\$138.86

Ergotron Laptop Cart

Neo-Flex

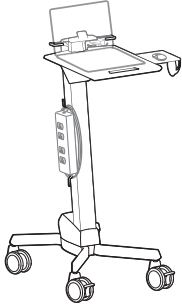

24-205-214
(power strip shown not included)
Class ER – GSA: Open Market

Features

- Includes: Integrated worksurface/keyboard tray with left/right mouse tray, scanner holder bracket, mouse holder, cable storage area, four dual casters (two locking), laptop security system, bracket for power strip and cable wrap.
- Compatible with most 12"(305mm)-17"(432mm) laptops. Maximum outside width of laptop is 18"(457mm).
- Maximum weight capacity is 15 pounds.
- Front handle on worksurface allows for easy mobility.
- 20"(508mm) height range adjustment allows for use from a seated or standing position.
- Worksurface dimensions 16.5"(419mm)W x 20.5"(521mm)D.
- Laptop cart standard in gray with 2 piece gray plastic worksurface.

To Order, Specify:

- 1) Product number.

Height	Depth	Width	Number	Price
26.6"(676mm)-46.6"(1184mm)	22.8"(579mm)	17.5"(445mm)	24-205-214	\$2286.61

Ergotron Mobile Digital Workspace Teachwell®

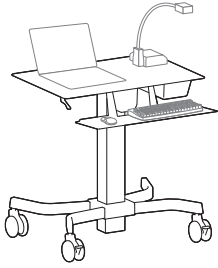

24-220-055
Class ER – GSA: Open Market

Features

- Includes: Cart, integrated phenolic worksurface, seamless keyboard/mousing tray, cable management box, cable winding brackets, four dual casters (two locking).
- Maximum weight capacity 38.5 pounds.
- Worksurface height adjustment range: 32"(813mm)-52"(1321mm).
Note: worksurface and keyboard tray adjust in tandem.
- Worksurface dimensions: 31"(787mm)W x 21"(533mm)D.
- Keyboard Tray: 26"(660mm)W x 9.4"(239mm)D stows under worksurface. Includes 5° back-tilt.
- Cable management box interior: 13.4"(340mm)W x 5"(127mm)D x 3.4"(86mm)H. Provides storage for one standard six-outlet power strip, two power bricks and the associated cables.
- Available in supplier graphite grey only.
- Includes mechanical mounting holes to mount many major document camera models. Ordered separately.
- Ships assembled.

To Order, Specify:

- 1) Product number.

Description	Depth	Width	Number	Price
32"(813mm)-52"(1321mm)	24"(610mm)	31"(787mm)	24-220-055	\$2082.93

Ergotron Keyboard Tray

Keyboard Tray with Mouse Pad

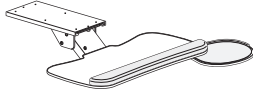

169BK

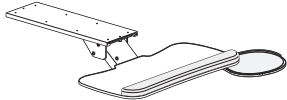

UKMOBK

Class ER - GSA: Open Market

Features

- Includes: Keyboard tray with mouse pad and attachment hardware.
- Keyboard tray includes integrated foam wrist rest.
- Oval mouse extension pivots out from the right side.
- Height adjustment range: Level with to 6"(152mm) below worksurface.
- Tilt adjustment -20°/ +10°
- Pans 360°.
- Available with 11"(279mm) track or 18.5"(470mm) track.
- Weight capacity: 10 lbs.
- Black only.
- TAA Compliant.

Specification Tips

- Keyboard tray extends 4"(102mm) from front of worksurface when retracted.
- 11"(279mm) or 18.5"(470mm) under surface depth required for track installation.

To Order, Specify:

- 1) Product number.

Description	Height Adjustment	Number	Price
11"(279mm) Track	0" Above/6" Below	169BK	\$808.42
18.5"(470mm) Track	0" Above/6" Below	UKMOBK	812.37

Neo-Flex Keyboard Tray

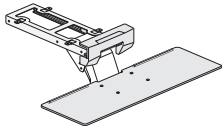

97-582-009

Class ER - GSA: Open Market

Features

- Includes: Keyboard tray, arm, desk clamp, slide mechanism and mounting hardware.
- Height adjustment range: Level with to 6"(152mm) below worksurface.
- Tilt adjustment +15°
- Fully retracts under worksurface when not in use.
- 26.9"(683mm)W x 8.9"(226mm)D keyboard trays allows room for keyboard and mouse.
- Weight capacity: 3 lbs.
- Keyboard tray extends approximately 9.25"(235mm) from front of surface.
- 15"(381mm) track.
- Black only.

Specification Tips

- Clamps to front edge of worksurface with clamp and one screw or remove clamp and attach under worksurface with four screws.
- Compatible with surfaces .75"(19mm)-1.5"(25mm) thick.
- For use on surfaces with minimum depth of 17".

To Order, Specify:

- 1) Product number.

Description	Height Adjustment	Number	Price
Keyboard Tray	0" Above/6" Below	97-582-009	\$438.76

Ergotron CPU Holder

Small CPU Holder



80-063-216
Class ER - GSA: Open Market

Features

- Includes: One vertical steel CPU holder, mounting hardware and fasteners.
- Mounts to any sturdy vertical surface.
- CPU Holder is 6"(152mm)H x 10"(254mm)D.
- Accommodates CPUs 1.4"(25mm) to 3.75"(76mm)W.
- Weight capacity: 50 lbs.

To Order, Specify:

- 1) Product number.

Description	Number	Price
White	80-063-216	\$193.64

Universal CPU Holder

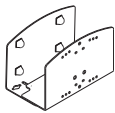

97-468-202
97-468-216
Class ER - GSA: Open Market

Features

- Includes: One vertical steel CPU holder, mounting hardware and fasteners.
- Mounts to any sturdy vertical surface.
- CPU Holder is 6.6"(152mm)H x 10"(254mm)D.
- Accommodates CPUs 2"(51mm)-8"(203mm)W.
- Weight capacity: 40 lbs.

To Order, Specify:

- 1) Product number.

Description	Number	Price
Silver	97-468-202	\$250.37
White	97-468-216	250.37

Cable CPU Holder



80-105-064
Class ER - GSA: Open Market

Features

- Includes: One size-adjustable CPU holder and hardware.
- Mounts directly to wall or under worksurface.
- Size adjusts from 9.4"(229mm) x 2.6"(51mm) to 18"(457mm) x 8.5"(203mm).
- Unique security fasteners deter theft.
- Weight capacity: 50 lbs.

To Order, Specify:

- 1) Product number.

Description	Number	Price
Grey/Silver	80-105-064	\$157.69

Anti-Fatigue Floor Mat

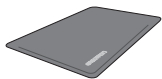

97-620-060
Class ER - GSA: Open Market

Features

- Includes: One floor mat.
- 0.625"(16mm) thick.
- Custom blended medium density polyurethane foam.
- High tear strength polyurethane outer membrane.
- Black only.
- TAA (Trade Agreements Act) compliant.

To Order, Specify:

- 1) Product number.

Description	Depth	Width	Number	Price
6.25"(159mm)	24"(610mm)	36"(914mm)	97-620-060	\$724.44

Lighting

Task

Adaptable LED Task Light – Stand Alone

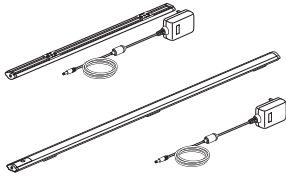

LUTN
Class YA – GSA Open Market

Features

- Includes 17”(432mm), 31”(787mm) or 44”(1118mm) LED fixture, 18 watt power supply with black nine foot power cord, two adhesive cord managers and screw/magnetic attachment hardware.
- Standard in anodized (silver) color with black caps.
- Height: 0.5”(13mm); Width: 1.18”(30mm).
- Automatic turn off after 12 hours (+/- 15 mins).

Specification Tips

- For use with 120 volt, 60 hertz electrical system.
- Color Temp: 3500K.
- Color Rendition Index: 82+ CRI.
- Rated Lifespan: >43,800 hour.
- **Not intended for daisy chaining.**
- Single touch on/off with continuous dimming from 15-100% with last state memory.
- Intended for use under shelf or cabinet.

To Order, Specify:

- 1) Product number.
(No finish specification required.)

Fixture Length	Total Length with Switch	Watts	Number	Price
17”(432mm)	18.8”(478mm)	5.6	LUTN-0017-19ULDN	\$268.98
31”(787mm)	32.8”(833mm)	10.3	LUTN-0031-19ULDN	305.38
44”(1118mm)	45.8”(1163mm)	14.3	LUTN-0044-19ULDN	339.18

Adaptable LED Task Light – Starter Kit

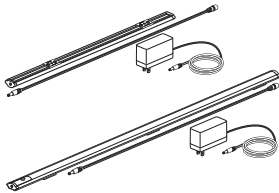

LUTT
Class YA – GSA Open Market

Features

- Includes LED fixture, 65 watt power supply with ten foot power cord, two adhesive cord managers, and screw/magnetic attachment hardware.
- Standard in anodized (silver) color with black caps.
- Height: 0.5”(13mm); Width: 1.18”(30mm).
- Automatic turn off after 12 hours (+/- 15 mins).

Specification Tips

- For use with 120 volt, 60 hertz electrical system.
- Color Temp: 3500K.
- Color Rendition Index: 82+ CRI.
- Rated Lifespan: >43,800 hour.
- Refer to the Specification Guide or under the Adaptable LED Task Light - Add-On Kit for a chart showing the total number of light fixtures that can be daisy chained together.
- Single touch on/off with continuous dimming from 15-100% with last state memory.
- The on/off dimmer switch on the Starter Kit fixture will control all connected Add-On lights.
- Intended for use under shelf or cabinet.

To Order, Specify:

- 1) Product number.
(No finish specification required.)

Fixture Length	Total Length with Switch	Watts	Number	Price
17”(432mm)	18.8”(478mm)	5.6	LUTT-0017-11ULDN	\$305.15
31”(787mm)	32.8”(833mm)	10.3	LUTT-0031-11ULDN	341.55
44”(1118mm)	45.8”(1163mm)	14.3	LUTT-0044-11ULDN	375.35

Lighting

Task

Adaptable LED Task Light – Add-On Kit

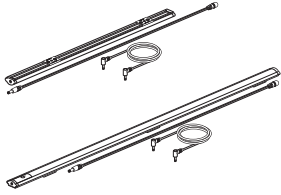

LUTA
Class YA – GSA Open Market



Features

- Includes LED fixture, 30”(762mm) daisy chain cord, two adhesive cord managers, and screw/magnetic attachment hardware.
- Standard in anodized (silver) color with black caps.
- Height: 0.5”(13mm); Width: 1.18”(30mm).

Specification Tips

- For use with 120 volt, 60 hertz electrical system.
- Color Temp: 3500K.
- Color Rendition Index: 82+ CRI.
- Rated Lifespan: >43,800 hour.
- Refer to the chart at right for the total number of light fixtures that can be daisy chained together.
- The on/off dimmer switch on the Starter Kit fixture will control all connected Add-On lights.
- Intended for use under shelf or cabinet.

To Order, Specify:

- 1) Product number.
(No finish specification required.)

Acceptable Daisy Chain Light Combinations

Daisy Chain Combinations	# of 17” Lights	# of 31” Lights	# of 44” Lights
Combination 1	1	1	1
Combination 2	1	1	0
Combination 3	1	2	0
Combination 4	1	0	1
Combination 5	2	1	0
Combination 6	2	0	1
Combination 7	2	0	0
Combination 8	3	1	0
Combination 9	3	0	0
Combination 10	4	0	0
Combination 11	0	1	1
Combination 12	0	2	0
Combination 13	0	3	0
Combination 14	0	0	2

Fixture Length	Watts	Number	Price
17”(432mm)	5.6	LUTA-0017-1NULDN	\$226.51
31”(787mm)	10.3	LUTA-0031-1NULDN	262.91
44”(1118mm)	14.3	LUTA-0044-1NULDN	296.71

Lighting

Reed Premier™

Stand-Alone LED Task Light

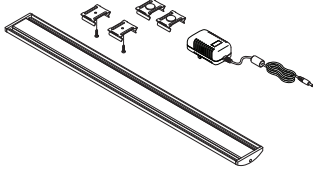

LUTS-0017-19ULD5



Class YA

Features

- Includes 17"(432mm) LED fixture, 15 watt power supply with nine foot removable power cord.
- Standard in anodized (silver) color with white end caps.
- 0.5"(13mm)H x 2.0"(51mm)W.

Specification Tips

- For use with 120 volt, 60 hertz electrical system.
- Color Temp: 3500K.
- Color Rendition Index: 84 CRI.
- Rated Lifespan: 50,000 hour.
- Not intended for daisy chaining.
- Single touch on/off with continuous dimming from 15-100%.
- Automatic shutoff after 10 hours.
- Includes screw and magnetic attachment hardware for steel, laminate and wood.
- Intended for use in horizontal applications.

To Order, Specify:

- 1) Product number.
(No finish specification required.)

Fixture Length	Watts	Number	Price
16.4"(417mm)	7.8	LUTS-0017-19ULD5	\$403.51

Starter LED Task Light

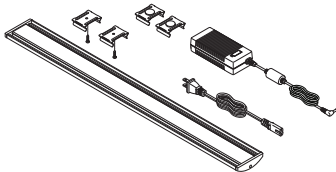

LUTS-0017-12ULD6



Class YA

Features

- Includes LED fixture, 60 watt power supply with twelve foot removable power cord.
- Standard in anodized (silver) color with white end caps.
- 0.5"(13mm)H x 2.0"(51mm)W.

Specification Tips

- For use with 120 volt, 60 hertz electrical system.
- Color Temp: 3500K.
- Color Rendition Index: 84 CRI.
- Rated Lifespan: 50,000 hour.
- Refer to the Specification Guide for a chart showing the total number of light fixtures that can be daisy chained together.
- Single touch on/off with continuous dimming from 15-100%.
- Automatic shutoff after 10 hours.
- Includes screw and magnetic attachment hardware for steel, laminate and wood.
- Intended for use in horizontal applications.

To Order, Specify:

- 1) Product number.
(No finish specification required.)

Fixture Length	Watts	Number	Price
16.4"(417mm)	7.8	LUTS-0017-12ULD6	\$ 554.84
30.1"(765mm)	17.6	LUTS-0031-12ULD6	807.40
43.7"(1110mm)	25.9	LUTS-0044-12ULD6	1041.92
57.4"(1458mm)	33.6	LUTS-0058-12ULD6	1294.48

Lighting

Reed Premier™

Task Light Add-On Kit

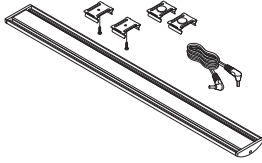

LUTD-0017-1NULDN



Class YA

Features

- Includes LED fixture, 8”(203mm) and 30”(762mm) daisy chain cord.
- Standard in anodized (silver) color with white end caps.
- 0.5”(13mm)H x 2.0”(51mm)W.

Specification Tips

- For use with 120 volt, 60 hertz electrical system.
- Color Temp: 3500K.
- Color Rendition Index: 84 CRI.
- Rated Lifespan: 50,000 hour.
- Refer to the Specification Guide for a chart showing the total number of light fixtures that can be daisy chained together.
- Single touch on/off with continuous dimming from 15-100%.
- Automatic shutoff after 10 hours.
- Includes screw and magnetic attachment hardware for steel, laminate and wood.
- Intended for use in horizontal applications.

To Order, Specify:

- 1) Product number.
(No finish specification required.)

Fixture Length	Watts	Number	Price
16.4”(417mm)	7.8	LUTD-0017-1NULDN	\$403.51
30.1”(765mm)	17.6	LUTD-0031-1NULDN	656.07
43.7”(1110mm)	25.9	LUTD-0044-1NULDN	890.59
57.4”(1458mm)	33.6	LUTD-0058-1NULDN	1143.15

Add-On Occupancy Sensor

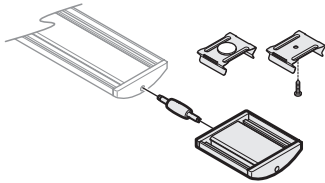

LUTS-0000



Class YA

Features

- Includes occupancy sensor and attachment connector.
- Standard in anodized (silver) color with white end caps.
- 0.7”(18mm)H x 2.0”(51mm)W.

Specification Tips

- For use with 120 volt, 60 hertz electrical system.
- Includes screw and magnetic attachment hardware for steel, laminate and wood.
- Intended for use in horizontal applications.

To Order, Specify:

- 1) Product number.
(No finish specification required.)

Length	Number	Price
2.3”(58mm)	LUTS-0000	\$454.00

Lighting

Voyage

Without Occupancy Sensor

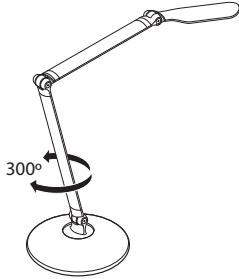

LUV1



Class YA - GSA: Open Market

Features

- Includes base, adjustable arm fixture with LED light and 6'(182cm) removable cord.
- Available in supplier silver, white or black.
- Touch controls for On/Off switching and continuous 100-15% dimming.
- Arm rotates 300°.
- Base footprint: 6"(152mm) diameter.
- Clamp mount can be used on horizontal surfaces from 0.90"(23mm) to 1.87"(47mm) thick.
- Auto turn off after 10 hours of use.
- Power consumption: 7W.
- Color temperature 3500k.
- Luminosity: 250 Lumens.
- Color Rendition Index: 84 CRI.
- 50K hour lifespan.
- Cord length: 6'(182cm)

Specification Tips

- Minor assembly required.
- **For use with 120 volt 60 hertz electrical system.**

To Order, Specify:

1) Product number, including:

1 Attachment:

- F** Freestanding
- G** Clamp

2) Trim color.

- TR-11 Black
- TR-12 Silver
- TR-13 White

Number

LUV1-0012-07 LC

Price

\$875.08

With Occupancy Sensor

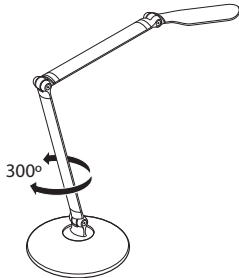

LUV2



Class YA - GSA: Open Market

Features

- Includes base, adjustable arm fixture with LED light and 6'(182cm) removable cord.
- Available in supplier silver, white or black.
- Touch controls for On/Off switching and continuous 100-15% dimming.
- Arm rotates 300°.
- Base footprint: 6"(152mm) diameter.
- Clamp mount can be used on horizontal surfaces from 0.90"(23mm) to 1.87"(47mm) thick.
- Power consumption: 7W.
- Color temperature 3500k.
- Luminosity: 250 Lumens.
- Color Rendition Index: 84 CRI.
- 50K hour lifespan.
- Cord length: 6'(182cm).

Specification Tips

- Minor assembly required.
- **For use with 120 volt 60 hertz electrical system.**

To Order, Specify:

1) Product number, including:

1 Attachment:

- F** Freestanding
- G** Clamp

2) Trim color.

- TR-11 Black
- TR-12 Silver
- TR-13 White

Number

LUV2-0012-07 LO

Price

\$1286.91

Storage — Suspended

Belong

Suspended Pedestal

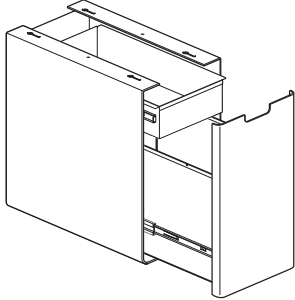

KUPA

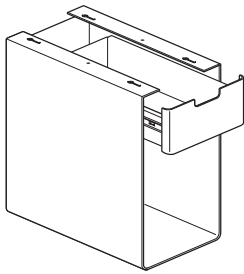

KUPD
Class YA1

Features

- Includes painted steel box/file pedestal or open pedestal with box drawer and attachment hardware.

Specification Tips

- Separately specified accessories, if applicable:
 - Drawer Liner
 - Drawer Tray
 - Magnetic Divider
 - File Partition
- For use on height adjustable configurations 29"(737mm)D or greater. See chart.
- Also for use on:
 - Intuity
 - Panel-mounted Adaptable Worksurfaces
- Pedestal must be mounted inside of the frame end bracket on all height adjustable tables.

To Order, Specify:

- 1) Product number.
- 2) Trim color.

Nominal Height	Nominal Depth	Nominal Width	Number	Trim A	B
Box/File					
16"(406mm)	17"(432mm)	9"(229mm)	KUPA-1609-SNSUNN	\$1072.37	\$1114.49
Box Drawer/Open					
16"(406mm)	17"(432mm)	9"(229mm)	KUPD-1609-SNSUNN	\$803.86	\$845.98

Product Line	Product Type	Worksurface Shape	Worksurface Width	Glides/Caster	Table Height Range	Belong Suspended Storage Max Load *Including weight of ped	New Max Work Load *including worksurface
Upside	Upside Height Adjustable Table	Rectangle	>=58"	Glides or Caster	Single Stage (Standard)	70 lbs.	150 lbs.
			90		>58"	Glides	Dual Stage (Extended)
		120	>=46"	Single Stage (Standard)	70 lbs.		250 lbs.
				Dual Stage (Extended)	50 lbs.	200 lbs.	
	Upside Height Adjustable Benching	Rectangle	>=58"	Glides	Single Stage (Standard)	70 lbs.	250 lbs.
			90		>58"	Dual Stage (Extended)	50 lbs.
		120	>=46"	Single Stage (Standard)	70 lbs.	250 lbs.	
				Dual Stage (Extended)	50 lbs.	200 lbs.	
Planes	Planes Height Adjustable Table *installation with differ	Rectangle	>=58"	Glides or Caster	Single Stage (Standard)	70 lbs.	150 lbs.
			90		>=58"	Glides	Dual Stage (Extended)
		120	>=46"	Single Stage (Standard)	70 lbs.		200 lbs.
				Dual Stage (Extended)	50 lbs.	150 lbs.	
	Planes Height Adjustable Benching *installation will differ	Rectangle	>=58"	Glide	Single Stage (Standard)	70 lbs.	150 lbs.
			90		>=58"	Dual Stage (Extended)	50 lbs.
		120	>=46"	Single Stage (Standard)	70 lbs.	200 lbs.	
				Dual Stage (Extended)	50 lbs.	150 lbs.	
Planes LT	Planes LT Height Adjustable Table	Rectangle	>58"	Glides or Caster	Single Stage (Standard)	50 lbs.	100 lbs.
			90		>=58"	Glides	Dual Stage (Extended)
		120	>=46"	Single Stage (Standard)	50 lbs.		200 lbs.
				Dual Stage (Extended)	50 lbs.	200 lbs.	
	Planes LT Height Adjustable Benching	Rectangle	>=58"	Glide	Single Stage (Standard)	50 lbs.	100 lbs.
			90		>=58"	Dual Stage (Extended)	50 lbs.
		120	>=46"	Single Stage (Standard)	50 lbs.	200 lbs.	
				Dual Stage (Extended)	50 lbs.	200 lbs.	

Storage — Suspended

Belong

Security Drawer

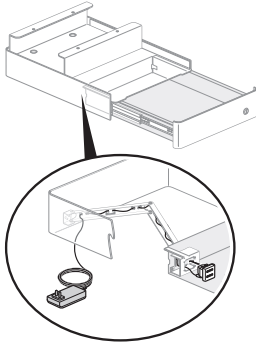

AHDD-SU
Class YA – GSA: Open Market

Features

- Includes a painted steel drawer and front with lock.
- Available with optional USB power (Retrofit USB Charging Cable EUDX-U000-).
- For lock options, refer to Lock Program section of the Accessories Price List.
- Drawer is 3”(76mm)H.
- Bracket designed to clear desking understructure.

Specification Tips

- Built-in top shelf 2”(51mm) from bottom of worksurface.
- Designed to be used on:
 - Upside, Planes and Planes LT Benching configurations 29”(737mm)D or greater.
 - Freestanding Height Adjustable Tables 29”(737mm)D or greater:
 - Upside C-Leg
 - Planes and Planes LT C-Leg
 - Intuity Benching
 - Adaptable Worksurfaces
- Security Drawer without power option cannot be retrofit with power option.
- A power supply attached to the worksurface should be used when Security Drawer with USB option is located on Height Adjustable Tables or Benching.

To Order, Specify:

1) Product number, including:

1 Power Option:

N Non-Powered

U USB Power (add **\$122.32** list)

2) Case trim color.

3) Front trim color.

4) Lock trim color.

Note: For mixed grade surfaces, please refer to the design and specification tools.

Nominal Height	Nominal Depth	Nominal Width	Number	①	Trim A	B
5”(127mm) Track	17”(432mm)	12”(305mm)	AHDD-0312-SU	■ NL	\$876.74	\$909.38

Storage — Suspended Accessories

Belong

Top Liner — Security Drawer

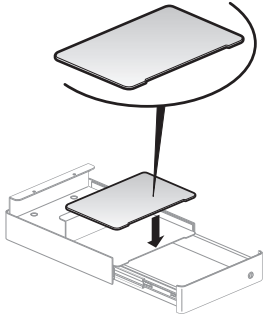

ALTD-S
Class YA – GSA: Open Market

Features

- Includes one steel liner and double sided tape.

Specification Tips

- Painted steel liner sits on top of built-in top shelf.
- Painted steel liner is not for drawer body.

To Order, Specify:

- 1) Product number.
- 2) Trim color.

Depth	Width	Number	Trim	
			A	B
8”(203mm)	12”(305mm)	ALTD-0812-S	\$111.25	\$116.34

Drawer Liner

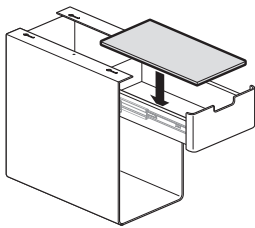

ALDD-F
Class YA – GSA: Open Market

Features

- Includes one felt liner.

Specification Tips

- Designed to be used with:
 - Belong pedestal
 - Security Drawer
 - Drawer Tray

To Order, Specify:

- 1) Product number.
- (No finish specification required.)

Application	Height	Width	Number	Price
Security Drawer	17”(432mm)	12”(305mm)	ALDD-1712-F	\$46.40
Tray	17”(432mm)	7”(178mm)	ALDT-0607-F	24.48

File Partition

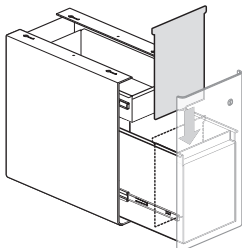

AAOP-S
Class YA – GSA: Open Market

Features

- Includes one painted steel partition.
- Attaches in file drawer of suspended pedestal for letter filing.

To Order, Specify:

- 1) Product number.
- 2) Trim color.

Height	Width	Number	Trim	
			A	B
10”(254mm)	6”(152mm)	AAOP-1007-S	\$67.18	\$71.23

Drawer Tray

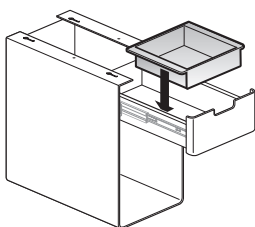

AAOT-S
Class YA – GSA: Open Market

Features

- Includes one painted steel tray.

Specification Tips

- Separately specified if applicable:
 - Drawer Liner
 - Magnetic Divider
- Can be used with Belong Suspended Pedestal.

To Order, Specify:

- 1) Product number.
- 2) Trim color.

Height	Width	Number	Trim	
			A	B
2”(51mm)	7”(178mm)	AAOT-0207-S	\$240.30	\$242.35

Storage Accessories

Belong

PDA Tray

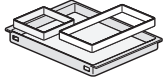

KJTY-12
Class YA

Features

- Includes one rectangular PDA tray, one small ring, and one large ring.
- PDA Tray:
 - Outside dimensions - 1.38"(35mm)H x 11.75"(298mm)W x 16.12"(409mm)L
 - Inside dimensions - 1.25"(32mm)H x 11.5"(292mm)W x 12.87"(327mm)L
- Small ring:
 - Outside dimensions - 1"(25mm)H x 5.55"(141mm)W x 5.55"(141mm)L
- Large ring:
 - Outside dimensions - 1"(25mm)H x 5.98"(152mm)W x 11.43"(290mm)L
- PDA Tray has cutouts to allow for low voltage cable management.
- PDA Tray and rings are plastic.
- Standard in Snow trim.

Specification Tips

- PDA Tray designed to be used as a stand alone accessory in X Series, Masters Series and Compose Storage file drawers.
- Designed to slide side-to-side along the panels, or hanging bars in file drawers, allowing access to drawer contents below the PDA Tray.
- Files cannot be hung in lateral file drawers when using the PDA Tray.

Note: Snow (TR-FM) plastic trim color is not recommended for use with painted trim colors Plaster (TR-TW) or Chalk (TR-AK). Refer to Very® Seating chainset for Snow.

To Order, Specify:

- 1) Product number.
(No finish specification required.)

	Number	Price
	KJTY-12	\$59.70

Personal Tray

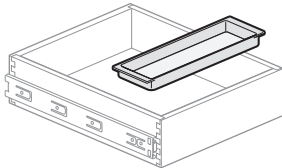

KJTY-10
Class YA - GSA: Open Market

Features

- Includes one rectangle plastic tray.
- Outside dimensions: 1.38"(35mm)H x 5.88"(149mm)W x 12.87"(327mm)L
- Inside dimensions: 1.25"(32mm)H x 5.63"(143mm)W x 11.5"(292mm)L
- Can be used as a freestanding accessory in X Series lateral files, X Series Pedestal, Masters Series Pedestal and Compose Storage Pedestal.
- Standard in black.

To Order, Specify:

- 1) Product number.
(No finish specification required.)

Height	Depth	Width	Number	Price
1.38"(35mm)	5.88"(149mm)	12.87"(327mm)	KJTY-10	\$50.83

Pencil Tray

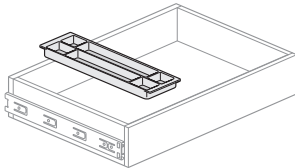

KJTY-9
Class YA

Features

- Includes one plastic tray.
- Suspends from X Series hanging bars; Masters Series 6"(152mm) drawer.
- Standard in black.

Specification Tips

- Files cannot be hung in X Series lateral file drawers when using the Pencil tray.

To Order, Specify:

- 1) Product number.
(No finish specification required.)

Height	Depth	Width	Number	Price
1.25"(32mm)	5.5"(140mm)	16.3"(414mm)	KJTY-9	\$67.69

Magnetic Divider

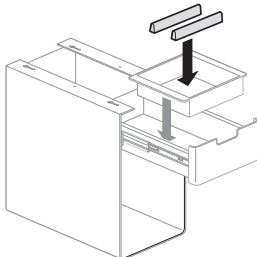

AAOD-S
Class YA - GSA: Open Market

Features

- Includes one magnetic aluminum divider.

Specification Tips

- Designed to be used with:
 - Security Drawer
 - Drawer Tray

To Order, Specify:

- 1) Product number.
- 2) Trim color.

Description	Depth	Width	Number	Trim	
				A	B
Drawer Tray	1"(25mm)	7"(178mm)	AAOD-0107-S	\$46.96	\$ 51.55
Security Drawer		12"(305mm)	AAOD-0112-S	57.21	64.35

Storage Accessories

Belong

Cushion Top

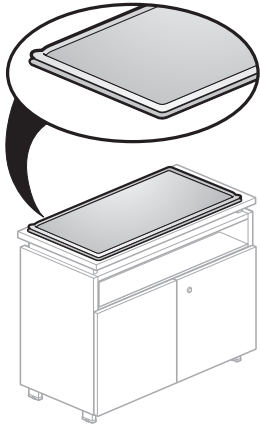

QBFC_F
Class YA

Features

- Includes one cushion and non-slip material.
- .75"(19mm) thick cushion is cover stitched around perimeter edges.
- Cushion is inset 0.6"(15mm) from base unit perimeter edges.
- Cushion has a two-sided reversible surface; same fabric on both sides.

Specification Tips

- Cushion is not structural; to be used with a storage top.
- Cushion may be the same width or not as wide as the base unit.
- Patterned fabrics may not align on both sides of the cushion.
- Not for use on 16"(406mm)D storage.

To Order, Specify:

- 1) Product number.
- 2) Fabric and color.

Depth	Nominal Width	Actual Width	Number	Fabric Grade					
				A	B	C	D	E	F
16.8"(427mm)	24"(610mm)	22.65"(559mm)	QBFC-1824-F	\$ 723.24	\$ 831.71	\$ 954.67	\$1084.85	\$ 1215.05	\$ 1395.84
	30"(762mm)	28.65"(711mm)	QBFC-1830-F	835.98	961.49	1103.41	1253.87	1404.47	1613.34
	36"(914mm)	34.65"(864mm)	QBFC-1836-F	948.72	1091.27	1252.15	1422.89	1593.89	1830.84
	42"(1067mm)	40.65"(1016mm)	QBFC-1842-F	1061.46	1221.05	1400.89	1591.91	1783.31	2048.34

Work Tools

Rails and Mounting

Slat, Wall Mount

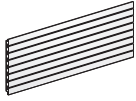

KUPY
Class CA

Features

- Includes slat tile & attachment brackets for structural wall.
- Belong and Jump Stuff work tools may be used; separately specified.

Specification Tips

- Designed to be used under wall mounted overhead storage units.
- Allows space for task light cord routing.
- **Not for use with wall track.**

To Order, Specify:

- 1) Product number.
- 2) Trim color.

Nominal Height	Width	Number	Trim	
			A	B
16"(406mm)	18"(457mm)	KUPY-1618	\$452.36	\$460.75
	24"(610mm)	KUPY-1624	489.71	500.18
	30"(762mm)	KUPY-1630	527.06	539.61
	36"(914mm)	KUPY-1636	564.41	579.04
	42"(1067mm)	KUPY-1642	601.76	618.47
	48"(1219mm)	KUPY-1648	639.11	657.90
	54"(1372mm)	KUPY-1654	676.46	697.33
	60"(1524mm)	KUPY-1660	713.81	736.76

Work Tools

Rails and Mounting

Single Side

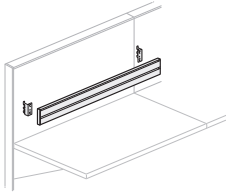

KURI-0424-PZN
Class YA

Features

- Includes one rail with panel attachment brackets.
- Mounts to panel side trim rails/connectors/slotted frame/wall track to support rail tools.
- Tool Rail is 0.625"(16mm) thick; brackets provide 0.375"(10mm) gap for cord management.
- Belong and Jump Stuff work tools may be used; separately specified.

Specification Tips

- **Supports maximum load of 40 pounds of Paper Management evenly distributed.**
- Panel mounted rail may span one or more panels equivalent to rail width.
- Recommended mounting position is approximately 9"(229mm) above worksurface.
- Rail is for use with specific product lines: Compose® and UniGroup Too®.

To Order, Specify:

- 1) Product number.
- 2) Trim Color for rail/brackets (product line specific; refer to appropriate price list).

Height	Depth	Width	Number	Trim	
				A	B
Compose					
4"(102mm)	1"(25mm)	24"(610mm)	KURI-0424-PZN	\$259.08	\$281.09
		30"(762mm)	KURI-0430-PZN	277.68	301.69
		36"(914mm)	KURI-0436-PZN	296.28	322.29
		42"(1067mm)	KURI-0442-PZN	314.88	342.89
		48"(1219mm)	KURI-0448-PZN	333.48	363.49
		54"(1372mm)	KURI-0454-PZN	352.08	384.09
		60"(1524mm)	KURI-0460-PZN	504.81	538.82
UniGroup					
4"(102mm)	1"(25mm)	24"(610mm)	KURI-0424-PEN	\$259.08	\$281.09
		30"(762mm)	KURI-0430-PEN	277.68	301.69
		36"(914mm)	KURI-0436-PEN	296.28	322.29
		42"(1067mm)	KURI-0442-PEN	314.88	342.89
		48"(1219mm)	KURI-0448-PEN	333.48	363.49
		60"(1524mm)	KURI-0460-PEN	504.81	538.82

Work Tools

Rails and Mounting

Tool Rail — Horizontal Surface Mount C-Clamp or Thru-Mount

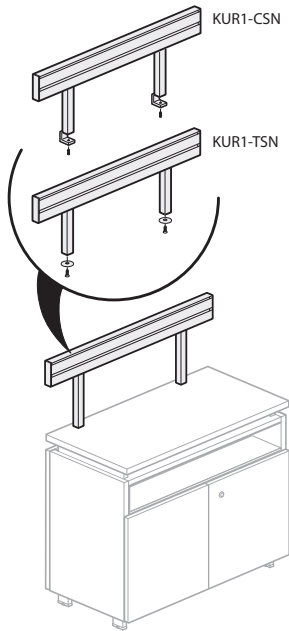

KURI-1224-CSN
Class YA

Features

- Includes one double sided rail with two posts, two rail end caps and attachment hardware.
- Mounts to horizontal surface to support rail tools.
- 1.18"(30mm) C-clamp Rail mounts on horizontal surfaces from 0.75"(19mm) to 1.75"(44mm) thick.
- Thru-mount Rail mounts on 1.18"(25mm) thick horizontal surfaces.
- Posts are 1.25"(32mm) thick.
- Belong and Jump Stuff work tools may be used; separately specified.
- Rail overall height above horizontal surface: 11.81"(300mm).
- Distance between rail bottom and top of horizontal surface: 7.44"(189mm).
- Ships unassembled.

Specification Tips

- Designed for single sided benching applications.
- **Not designed to be used in front of panel mounted accessories (tackboard, markerboard).**
- Tool Rail supports a maximum load of 40 pounds evenly distributed on user side.
- If supporting two monitor arms (up to 13 pounds each); an additional C-clamp or thru-mount post is recommended.
- Rail may be installed off modular.
- Heavy load application; additional posts can be ordered.
- Monitor arm cannot be mounted in post positions.
- Thru-mount post can be attached flush to back edge of horizontal surface.
- C-clamp rail can be attached to panel mounted horizontal surface with notch or radius wireways without removing the horizontal surface.
- Under horizontal surface: 4"(102mm) of clearance is necessary between back of horizontal surface and adjacent component for clamp attachment.
- Gap between screen and horizontal surface allows installation of Belong Tool Rail.
- Utility tray provides clearance for installation of Belong Tool Rail.

Note: No more than 6"(152mm) of rail can be extended beyond outside of support.

To Order, Specify:

- 1) Product number.
- 2) Trim color for rail/post.
- 3) Trim color for rail end caps:
 - TR-K Charcoal
 - TR-J Graphite
 - TR-FM Snow

Rail Height	Width	Description	Number	Trim	
				A	B
1.18"(30mm) Thick Top					
4"(102mm)	24"(610mm)	C-Clamp	KURI-1224-CSN	\$490.46	\$ 512.47
	30"(762mm)		KURI-1230-CSN	516.50	540.51
	36"(914mm)		KURI-1236-CSN	542.54	568.55
	42"(1067mm)		KURI-1242-CSN	568.58	596.59
	48"(1219mm)		KURI-1248-CSN	594.62	624.63
	54"(1372mm)		KURI-1254-CSN	620.66	652.67
60"(1524mm)		KURI-1260-CSN	780.83	814.84	
2"(51mm) Thick Top					
4"(102mm)	24"(610mm)	C-Clamp	KURI-1224-CMN	\$490.46	\$ 512.47
	30"(762mm)		KURI-1230-CMN	516.50	540.51
	36"(914mm)		KURI-1236-CMN	542.54	568.55
	42"(1067mm)		KURI-1242-CMN	568.58	596.59
	48"(1219mm)		KURI-1248-CMN	594.62	624.63
	54"(1372mm)		KURI-1254-CMN	620.66	652.67
60"(1524mm)		KURI-1260-CMN	780.83	814.84	
1.18"(30mm) Thick Top					
4"(102mm)	24"(610mm)	Thru-mount	KURI-1224-TSN	\$490.46	\$ 512.47
	30"(762mm)		KURI-1230-TSN	516.50	540.51
	36"(914mm)		KURI-1236-TSN	542.54	568.55
	42"(1067mm)		KURI-1242-TSN	568.58	596.59
	48"(1219mm)		KURI-1248-TSN	594.62	624.63
	54"(1372mm)		KURI-1254-TSN	620.66	652.67
60"(1524mm)		KURI-1260-TSN	780.83	814.84	
2"(51mm) Thick Top					
4"(102mm)	24"(610mm)	Thru-mount	KURI-1224-TMN	\$490.46	\$ 512.47
	30"(762mm)		KURI-1230-TMN	516.50	540.51
	36"(914mm)		KURI-1236-TMN	542.54	568.55
	42"(1067mm)		KURI-1242-TMN	568.58	596.59
	48"(1219mm)		KURI-1248-TMN	594.62	624.63
	54"(1372mm)		KURI-1254-TMN	620.66	652.67
60"(1524mm)		KURI-1260-TMN	780.83	814.84	

Work Tools

Rails and Mounting

Tool Rail — Single Post — C-Clamp or Thru-mount

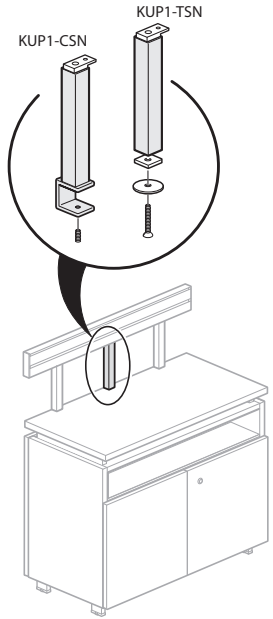

KUP1-0000-CSN
Class YA

Features

- Includes one C-clamp or one Thru-mount Post and attachment hardware.
- Posts mount on horizontal surfaces 1.18”(30mm)-2”(51mm) thick.
- Posts are 1.25”(32mm) thick.

Specification Tips

- Posts supports slide along rail bottom groove.
- For use with C-clamp or Thru-mount tool rail only.
- Monitor arm cannot be mounted in post position.
- Extra single posts can be ordered when additional support for monitor arms and paper management are attached to Tool Rail.

To Order, Specify:

- 1) Product number.
- 2) Trim color.

Post Height	Description	Number	Trim A	B
1.18”(30mm) Thick Top				
7.5”(191mm)	C-Clamp	KUP1-0000-CSN	\$152.12	\$164.13
2”(51mm) Thick Top				
7.5”(191mm)	C-Clamp	KUP1-0000-CMN	\$152.12	\$164.13
1.18”(30mm) Thick Top				
7.5”(191mm)	Thru-mount	KUP1-0000-TSN	\$152.12	\$164.13
2”(51mm) Thick Top				
7.5”(191mm)	Thru-mount	KUP1-0000-TMN	\$152.12	\$164.13

Tool Rail — Single Post — L-Bracket Mount

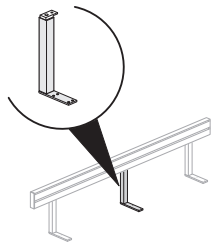

KUP1-0000-USN
Class YA

Features

- Includes one under horizontal surface L-Bracket mount post and attachment hardware.
- Post is 1.25”(32mm) thick.

Specification Tips

- For use with under horizontal surface mount tool rail.
- Single Support Post may interfere with central casting.
- Monitor arm cannot be mounted in post position.
- Extra single posts can be ordered when additional support for monitor arms and paper management are attached to Tool Rail.

To Order, Specify:

- 1) Product number.
- 2) Trim color.

Post Height	Number	Trim A	B
8.85”(225mm)	KUP1-0000-USN	\$152.12	\$164.13

Work Tools

Rails and Mounting

Tool Rail — Under Horizontal Surface Mount — L-Bracket

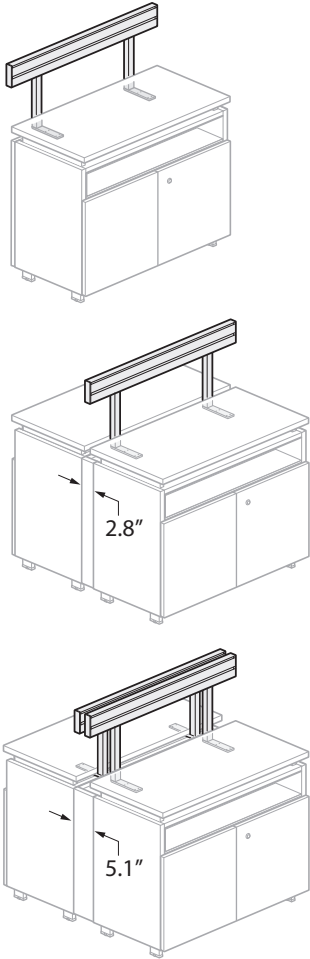

KUR1-1224-USN
Class YA

Features

- One double sided rail with two or three posts, two rail end caps and attachment brackets.
- Rails 66"(1676mm)-96"(2438mm) include three posts.
- L-bracket mounts under 1.18"(30mm) thick horizontal surface to support rail tools on both sides.
- Belong Work Tools or Jump Stuff Slat Pad Tools may be used; separately specified.
- Rail overall height above horizontal surface: 11.18"(284mm).
- Distance between rail bottom and top of horizontal surface: 7.44"(189mm).
- Post is 1.25"(32mm) thick.
- Ships unassembled.

Specification Tips

- **Rail with L-bracket or shared bracket mount can only be used in non-panel applications.**
- **Designed for single sided benching applications.**
- **Tool Rail supports a maximum load of 40 pounds (18.14kg) evenly distributed on user side or supports two monitor arms up to 13 pounds each; additional L-bracket mount post recommended.**
- For use with one base unit or back-to-back base units; L-Bracket Tool Rail is double sided to accommodate Belong work tool accessories on both sides.
- For back-to-back base unit applications, one or two L-Bracket tool rail(s) may be used:
 - One L-Bracket tool rail may be used between base units which results in an aesthetically unbalanced tool rail condition. Both users share a single tool rail. L-Brackets are attached to only one of the two back-to-back storage tops. (Note: KUR2-USN Under Worksurface Mount T-Bracket is not recommended for use with back-to-back base units due to installation issues.)
 - Two back-to-back L-Bracket tool rails may be used between base units for an aesthetically balanced tool rail condition.
 - For a single tool rail application, a 2.8"(71mm)D filler panel may be used to fill gap between back-to-back units.
 - For two back-to-back tool rails, a 5.1"(130mm)D filler panel may be used to fill gap between back-to-back base units.
- Tool Rail should be specified 6"(152mm) shorter than screen if both are specified.
- Can be installed off modular.
- Under horizontal surface: 4"(102mm) of clearance is necessary between back of horizontal surface and adjacent component for flat bracket attachment.
- Heavy load application; additional posts can be ordered.
- Monitor arm cannot be mounted in post positions.
- Gap between screen and horizontal surface allows installation of Belong Tool Rail.
- Utility tray provides clearance for installation of Belong Tool Rail.
- Posts mount flush to back edge of horizontal surface.

Note: No more than 6"(152mm) of rail can be extended beyond outside of support.

To Order, Specify:

- 1) Product number.
- 2) Trim color for rail/post.
- 3) Trim color for rail end caps:
 - TR-K Charcoal
 - TR-J Graphite
 - TR-FM Snow

Rail Height	Width	Number	Trim A	B
4"(102mm)	24"(610mm)	KUR1-1224-USN	\$ 490.46	\$ 512.47
	30"(762mm)	KUR1-1230-USN	516.50	540.51
	36"(914mm)	KUR1-1236-USN	542.54	568.55
	42"(1067mm)	KUR1-1242-USN	568.58	596.59
	48"(1219mm)	KUR1-1248-USN	594.62	624.63
	54"(1372mm)	KUR1-1254-USN	620.66	652.67
	60"(1524mm)	KUR1-1260-USN	780.83	814.84
	66"(1676mm)	KUR1-1266-USN	824.81	862.82
	72"(1829mm)	KUR1-1272-USN	868.79	906.80
	78"(1981mm)	KUR1-1278-USN	912.77	952.78
	84"(2134mm)	KUR1-1284-USN	956.75	998.76
	90"(2286mm)	KUR1-1290-USN	1000.73	1044.74
	96"(2438mm)	KUR1-1296-USN	1044.71	1090.72

Work Tools

Rails and Mounting

Tool Rail — Single Sided Continuous Benching End

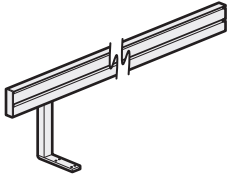

KUR1-1224-USE
Class YA

Features

- One single sided tool rail with one or two posts, one rail end cap and attachment brackets.
- Tool Rails 66"(1676mm)-96"(2438mm) includes two posts.
- Mounts under 1.18"(30mm) thick horizontal surface to support rail tools.
- Belong Work Tools or Jump Stuff Slat Pad Tools may be used; separately specified.
- Tool rail overall height above horizontal surface: 11.18"(284mm).
- Distance between tool rail bottom and top of horizontal surface: 7.44"(189mm).
- Post is 1.25"(32mm) thick.
- Ships unassembled.

Specification Tips

- **Designed for Single Sided Continuous Benching or continuous storage applications only.**
- **For use with another tool rail end or internal tool rail; internal benching single post must be specified.**
- **Tool Rail supports maximum of 40 pounds(18.14kg) evenly distributed on one side.**
- **For continuous benching application, two monitor arms up to 13 pounds each side, requires additional post.**
- **Tool Rail should be specified 6"(152mm) shorter than screen if both are specified.**
- Can be installed off modular.
- Under horizontal surface: 4"(102mm) of clearance is necessary between back of horizontal surface and pedestal for flat bracket attachment.
- Gap between screen and horizontal surface allows installation of Belong Tool Rail.
- Utility tray provides clearance for installation of Belong Tool Rail.

Note: No more than 6"(152mm) of rail can be extended beyond outside of support.

To Order, Specify:

- 1) Product number.
- 2) Trim color for tool rail/post.
- 3) Trim color for tool rail end cap:
 - TR-K Charcoal
 - TR-J Graphite
 - TR-FM Snow

Rail Height	Width	Description	Number	Trim A	B
4"(102mm)	24"(610mm)	End	KUR1-1224-USE	\$ 490.46	\$ 512.47
	30"(762mm)		KUR1-1230-USE	516.50	540.51
	36"(914mm)		KUR1-1236-USE	542.54	568.55
	42"(1067mm)		KUR1-1242-USE	568.58	596.59
	48"(1219mm)		KUR1-1248-USE	594.62	624.63
	54"(1372mm)		KUR1-1254-USE	620.66	652.67
	60"(1524mm)		KUR1-1260-USE	780.83	814.84
	66"(1676mm)		KUR1-1266-USE	824.81	862.82
	72"(1829mm)		KUR1-1272-USE	868.79	906.80
	78"(1981mm)		KUR1-1278-USE	912.77	952.78
	84"(2134mm)		KUR1-1284-USE	956.75	998.76
	90"(2286mm)		KUR1-1290-USE	1000.73	1044.74
	96"(2438mm)		KUR1-1296-USE	1044.71	1090.72

Work Tools

Rails and Mounting

Tool Rail — Double-Sided Continuous Benching End Application Only

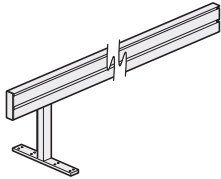

KUR2-1224-UBE
Class YA

Features

- One double sided tool rail with one or two posts, one rail end cap and attachment brackets.
- Tool Rails 66”(1676mm)-96”(2438mm) include two posts.
- Mounts under 1.18”(30mm) thick worksurface to support rail tools.
- Belong Work Tools or Jump Stuff Slat Pad Tools may be used; separately specified.
- Tool rail overall height above worksurface: 11.18”(284mm).
- Distance between tool rail bottom and top of worksurface: 7.44”(189mm).
- Post is 1.25”(32mm) thick.
- Ships unassembled.

Specification Tips

- **Designed for Continuous Benching applications only.**
- **For use with another tool rail end or internal tool rail; internal benching single post must be specified.**
- **Tool Rail supports maximum of 40 pounds(18.14kg) evenly distributed on each side.**
- **For continuous benching application, two monitor arms up to 13 pounds each side, requires additional post.**
- **Tool Rail should be specified 6”(152mm) shorter than screen if both are specified.**
- **For back-to-back application, 1 or 2 monitors up to 13 pounds each side, requires additional post.**
- Can be installed off modular.
- Under worksurface: 4”(102mm) of clearance is necessary between back of worksurface and pedestal for flat bracket attachment.
- Gap between screen and horizontal surface allows installation of Belong Tool Rail.
- Utility tray provides clearance for installation of Belong Tool Rail.
- Posts mount centered with 2.66”(68mm) gap.
- Refer to Specification, Class for planning rules.

Note: No more than 15”(152mm) of rail can be extended beyond outside of support.

To Order, Specify:

- 1) Product number.
- 2) Trim color for tool rail end cap:
- 3) Trim color for tool rail end cap:
 - TR-K Granite
 - TR-J Granite
 - TR-FM Silver

Rail Height	Width	Number	Trim	
			A	B
4”(102mm)	24”(610mm)	KUR2-1224-UBE	\$ 490.46	\$ 512.47
	30”(762mm)	KUR2-1230-UBE	516.50	540.51
	36”(914mm)	KUR2-1236-UBE	542.54	568.55
	42”(1067mm)	KUR2-1242-UBE	568.58	596.59
	48”(1219mm)	KUR2-1248-UBE	594.62	624.63
	54”(1372mm)	KUR2-1254-UBE	620.66	652.67
	60”(1524mm)	KUR2-1260-UBE	780.83	814.84
	66”(1676mm)	KUR2-1266-UBE	824.81	862.82
	72”(1829mm)	KUR2-1272-UBE	868.79	906.80
	78”(1981mm)	KUR2-1278-UBE	912.77	952.78
	84”(2134mm)	KUR2-1284-UBE	956.75	998.76
	90”(2286mm)	KUR2-1290-UBE	1000.73	1044.74
	96”(2438mm)	KUR2-1296-UBE	1044.71	1090.72

OBSOLETE! February 2026



Work Tools

Rails and Mounting

Tool Rail — Internal Single Sided Continuous Benching Application

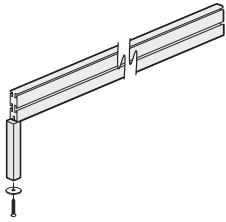

KUR1-1224-USI
Class YA

Features

- One single sided tool rail with one or two post and attachment brackets.
- Tool Rails 66"(1676mm)-96"(2438mm) includes two posts.
- Mounts on 1.18"(30mm) thick horizontal surface to support rail tools.
- Belong Work Tools or Jump Stuff Slat Pad Tools may be used; separately specified.
- Tool rail overall height above horizontal surface: 11.18"(284mm).
- Distance between tool rail bottom and top of horizontal surface: 7.44"(189mm).
- Post is 1.25"(32mm) thick.
- Ships unassembled.

Specification Tips

- **Designed for Single Sided Continuous Benching or continuous storage applications only.**
- **For use with two rail ends; Internal Benching single post must be specified.**
- **Tool Rail supports a maximum of 40 pounds(18.14kg) evenly distributed on one side.**
- **For use with benching application, 1 or 2 monitors up to 13 pounds each side, requires additional post.**
- Mounts into 0.25"(6mm) gap between shared block connectors or center attachment location on shared column.
- Under horizontal surface: 4"(102mm) of clearance is necessary between back of horizontal surface and pedestal for flat bracket attachment.
- Gap between screen and horizontal surface allows installation of Belong Tool Rail.
- Utility tray provides clearance for installation of Belong Tool Rail.

To Order, Specify:

- 1) Product number.
- 2) Trim color for tool rail/post.

Rail Height	Width	Description	Number	Trim	
				A	B
4"(102mm)	24"(610mm)	Internal	KUR1-1224-USI	\$ 490.46	\$ 512.47
	30"(762mm)		KUR1-1230-USI	516.50	540.51
	36"(914mm)		KUR1-1236-USI	542.54	568.55
	42"(1067mm)		KUR1-1242-USI	568.58	596.59
	48"(1219mm)		KUR1-1248-USI	594.62	624.63
	54"(1372mm)		KUR1-1254-USI	620.66	652.67
	60"(1524mm)		KUR1-1260-USI	780.83	814.84
	66"(1676mm)		KUR1-1266-USI	824.81	862.82
	72"(1829mm)		KUR1-1272-USI	868.79	906.80
	78"(1981mm)		KUR1-1278-USI	912.77	952.78
	84"(2134mm)		KUR1-1284-USI	956.75	998.76
	90"(2286mm)		KUR1-1290-USI	1000.73	1044.74
	96"(2438mm)		KUR1-1296-USI	1044.71	1090.72

Work Tools

Rails and Mounting

Tool Rail — Internal Continuous Benching Application Only

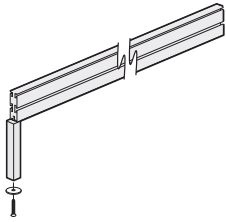

KUR2-1224-UBI
Class YA

Features

- One double sided tool rail with one or two post and attachment brackets.
- Tool Rails 66”(1676mm)-96”(2438mm) includes two posts.
- Mounts on 1.18”(30mm) thick horizontal surface to support rail tools.
- Belong Work Tools or Jump Stuff Slat Pad Tools may be used; separately specified.
- Tool rail overall height above horizontal surface: 11.18”(284mm).
- Distance between tool rail bottom and top of horizontal surface: 7.44”(189mm).
- Post is 1.25”(32mm) thick.
- Ships unassembled.

Specification Tips

- **Designed for Continuous Benching and continuous storage applications only.**
- **For use with two rail ends; Internal Benching single post must be specified.**
- **Tool Rail supports a maximum of 40 pounds(18.14kg) evenly distributed.**
- **Tool Rail should be specified 6”(152mm) shorter than screen if both are specified.**
- **For use with benching application, 1 or 2 monitors up to 13 pounds each side, requires additional post.**
- Mounts into 0.25”(6mm) gap between shared block connectors or center attachment location on shared column.
- Under horizontal surface: 4”(102mm) of clearance is necessary between back of horizontal surface and pedestal for flat bracket attachment.
- Gap between screen and horizontal surface allows installation of Belong Tool Rail.
- Utility tray provides clearance for installation of Belong Tool Rail.
- Posts mount center to center in 0.65”(93mm) gap.
- No more than 6”(152mm) rail can be extended beyond outside of support.

To Order, Specify:

- 1) Product number.
- 2) Trim color for tool rail/post.

Rail Height	Width	Description	Number	Trim A	B
4”(102mm)	24”(610mm)	Internal	KUR2-1224-UBI	\$ 490.46	\$ 512.47
	30”(762mm)		KUR2-1230-UBI	516.50	540.51
	36”(914mm)		KUR2-1236-UBI	542.54	568.55
	42”(1067mm)		KUR2-1242-UBI	568.58	596.59
	48”(1219mm)		KUR2-1248-UBI	594.62	624.63
	54”(1372mm)		KUR2-1254-UBI	620.66	652.67
	60”(1524mm)		KUR2-1260-UBI	780.83	814.84
	66”(1676mm)		KUR2-1266-UBI	824.81	862.82
	72”(1829mm)		KUR2-1272-UBI	868.79	906.80
	78”(1981mm)		KUR2-1278-UBI	912.77	952.78
	84”(2134mm)		KUR2-1284-UBI	956.75	998.76
	90”(2286mm)		KUR2-1290-UBI	1000.73	1044.74
	96”(2438mm)		KUR2-1296-UBI	1044.71	1090.72

Tool Rail — Single Post Internal/Benching

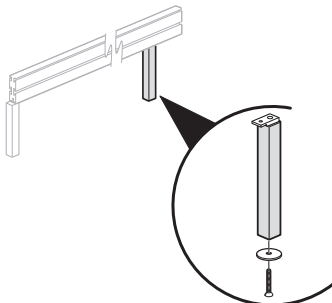

KUP2-0000-UBI
Class YA

Features

- Includes one Internal position post and attachment hardware.
- Post is 1.25”(32mm) thick.

Specification Tips

- For use with benching mount tool rail.
- Mounts into 0.25”(6mm) gap between shared block connectors or center attachment location on shared column.

To Order, Specify:

- 1) Product number.
- 2) Trim color.

Rail Height	Description	Number	Trim A	B
8.9”(226mm)	Internal	KUP2-0000-UBI	\$152.12	\$164.13

Work Tools

Belong

Open C Cubby

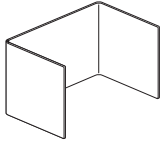

KUCU-0915-BNN

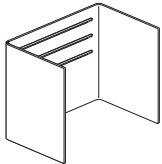

KUCU-1215-BNS
Class YA

Features

- Includes one freestanding Open C Cubby.
- Freestanding Open C Cubby's are designed for supporting binders and books.
- Open C Cubby with slots allows use of Belong Work Tools or Jump Stuff Slat Pad work tools; separately specified.

To Order, Specify:

- 1) Product number.
- 2) Trim color.

Height	Depth	Width	Description	Number	Trim	
					A	B
9"(229mm)	10"(254mm)	15"(381mm)	No Slots	KUCU-0915-BNN	\$ 175.52	\$ 196.40
12"(305mm)	10"(254mm)	15"(381mm)	No Slots	KUCU-1215-BNN	183.89	204.77
12"(305mm)	10"(254mm)	15"(381mm)	With Slots	KUCU-1215-BNS	204.77	225.65

Blotter

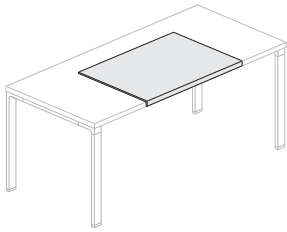

KUBL-2030-FJ
Class YA

Features

- Includes one blotter with protective back.
- Specify blotter profile to match desk edge:
 - 3mm Edgeband
 - Knife edge
- Belong Blotter radius is 0.5"(13mm).

To Order, Specify:

- 1) Product number.
- 2) Fabric

Specification Tips

- 20"(508mm)D blotter can be used on 24"(610mm)D desking without hatch.
- 20"(508mm)D blotter can be used on 30"(762mm)D desking with hatch.
- 24"(610mm)D blotter can be used on 36"(914mm)D desking with hatch.

Depth	Width	Edge	Number	Fabric Grade	
				D	E
19.7"(500mm)	29.5"(749mm)	3mm	KUBL-2030-FJ	\$852.54	\$900.85
19.7"(500mm)	35.4"(899mm)		KUBL-2036-FJ	873.52	926.02
23.6"(599mm)	35.4"(899mm)		KUBL-2436-FJ	894.50	951.19
19.7"(500mm)	29.5"(749mm)	Knife	KUBL-2030-FF	\$852.54	\$900.85
19.7"(500mm)	35.4"(899mm)		KUBL-2036-FF	873.52	926.02
23.6"(599mm)	35.4"(899mm)		KUBL-2436-FF	894.50	951.19

Reference Shelves

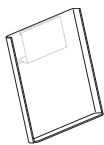

KURS-0010-H

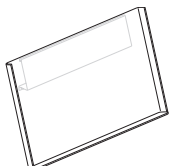

KURS-0019-H

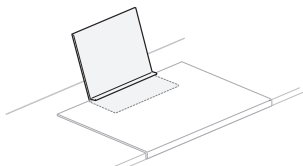

KURS-0012-B
Class YA

Features

- Includes one metal reference shelf
- Large and Small Reference shelves mount on:
 - Belong rail
 - Belong slat tile
 - Open C Cubby with slots
- Blotter Reference Shelf slides under blotter for support.

To Order, Specify:

- 1) Product number.
- 2) Trim color.

Specification Tips

- In installed position large and small referencing shelves are 0.88"(22mm)H and 4.3"(109mm)D.
- Reference shelf lip is 1.375"(35mm)D.

Height	Width	Description	Number	Trim	
				A	B
11.25"(286mm)	9.875"(251mm)	Reference — Small	KURS-0010-H	\$104.47	\$ 114.94
	18.5"(470mm)	Reference — Large	KURS-0019-H	156.72	167.19
9.875"(251mm)	11.625"(295mm)	Blotter Reference Shelf	KURS-0012-B	\$104.47	\$ 114.94

Work Tools

Belong

Base Tray

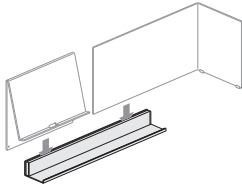

KUBT
Class YA – GSA: Open Market

Features

- Includes one freestanding steel Base Tray with aluminum insert rail.
- Base Tray is available with or without Accessory Kit.

Specification Tips

- Designed for use with L-Screen, Reference Shelf and Accessory Kit.
- L-Screen and Reference Shelf slide into space between steel back and aluminum insert.
- Base Tray accommodates one Reference Shelf and one L-Screen.
- Accessory Kit is designed to sit on 2.84”(72mm)D base tray ledge.

To Order, Specify:

- 1) Product number.
- 2) Trim color.

Actual Height	Actual Depth	Actual Width	Weight Pounds	Description	Number	Trim A	B
2.09”(53mm)	3.55”(90mm)	23.75”(603mm)	5.0 (2.3kg)	With Accessory Kit	KUBT-0224-A	\$545.96	\$566.05
				Without Accessory Kit	KUBT-0224-N	475.65	495.74

Desk Top L-Screen

Left-hand

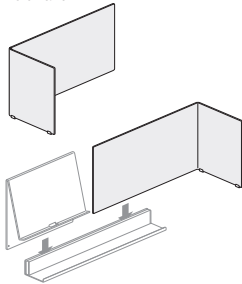

Right-hand
KULS
Class YA

Features

- Includes one steel Desk Top L-screen with semi-transparent plastic feet.
- Non-writable, magnetic surface.
- Desk Top L-Screen is handed.
- Supports maximum weight of 5 pounds (2.3kg).

Specification Tips

- Designed for use with Base Tray or as freestanding.
- Desk Top L-Screen may be used alone in Base Tray or with Reference Shelf.
- Depth portion of L-Screen, when used adjacent to Reference Shelf, is the same width as Base Tray; width portion of L-Screen perpendicularly wraps around Base Tray ledge.
- Width portion of Desk Top L-Screen may be positioned to fill Base Tray or a portion may overhang past end of Base Tray to accommodate Reference Shelf.

To Order, Specify:

- 1) Product number.
- 2) Trim color.

Actual Height	Actual Depth	Actual Width	Weight Pounds	Description	Number	Trim A	B
11.87”(301mm)	10”(254mm)	23.75”(603mm)	9.7 (4.4kg)	Right-hand	KULS-0000-TR	\$192.35	\$212.18
				Left-hand	KULS-0000-TL	192.35	212.18

Desk Top Reference Shelf

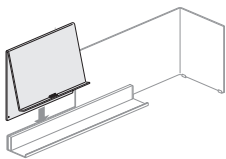

KURS
Class YA

Features

- Includes one steel desk Top Reference Shelf.
- Desk Top Reference Shelf lip is 1”(25mm)D with a 15 degree angle.
- Includes a cutout for cord drop if used for charging of electronic devices.
- Supports maximum weight of 5 pounds (2.3kg).
- Non-writable, magnetic surface.

Specification Tips

- Desk Top Reference Shelf may not be used alone in Base Tray; must be used together with Desk Top L-Screen for support purposes.
- Desk Top Reference Shelf is not freestanding.
- Desk Top Reference Shelf adjacent to depth portion of L-Screen are the same width as Base Tray; width portion of L-Screen perpendicularly wraps around Base Tray ledge.
- Desk Top Reference Shelf adjacent to width portion of L-Screen will overhang past end of Base Tray.

To Order, Specify:

- 1) Product number.
- 2) Trim color.

Actual Height	Actual Depth	Actual Width	Weight Pounds	Number	Trim A	B
12.03”(306mm)	4.25”(108mm)	14.5”(368mm)	8.1 (3.7kg)	KURS-0014-T	\$156.72	\$167.19

Work Tools

Belong

Trays

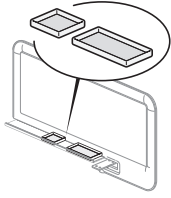

KUAK
Class YA

Features

- Includes one plastic tray.
- Sizes:
 - Square tray: 2.75"(70mm).
 - Rectangular tray: 2.75"(70mm) x 5.5"(140mm)

Specification Tips

- Designed for use with the Base Tray, Territory Screen or as freestanding pieces.

To Order, Specify:

- 1) Product number.
- 2) Trim color.
 - TR-R Beige
 - TR-1R Brownstone
 - TR-K Charcoal
 - TR-RR Rusty Red
 - TR-FM Snow

Description	Number	Price
Square Tray	KUAK-0000-NSN	\$213.22
Rectangular Tray	KUAK-0000-NNR	213.22

Paper Tray — Landscape

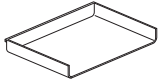

KUPT-0913-H

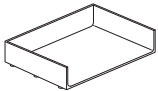

KUPT-0913-F
Class YA

Features

- Includes one plastic tray.
- Slat document tray mounts on Belong rail, Belong slat tile and Compose slat tile.
- Slat document tray supports maximum of one ream (5 pounds/2.3kg) of paper.
- Freestanding stacking tray is freestanding and stacks 4H.

Note: Snow (TR-FM) plastic trim color is not recommended for use with painted trim colors Plaster (TR-TW) or Chalk (TR-AK). Refer to Very® Seating chainset for Snow.

To Order, Specify:

- 1) Product number.
- 2) Trim color.
 - TR-R Beige
 - TR-1R Brownstone
 - TR-K Charcoal
 - TR-RR Rusty Red
 - TR-FM Snow

Height	Depth	Width	Description	Number	Price
1.5"(38mm)	8.875"(225mm)	12.75"(324mm)	Slat — Document Tray	KUPT-0913-H	\$43.88
2.5"(64mm)	8.875"(225mm)	12.75"(324mm)	Freestanding — Stacking Tray	KUPT-0913-F	52.25

Mini Shelf

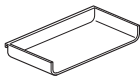

KUSH-0408-H
Class YA

Features

- Includes one plastic shelf.
- Mini shelf mounts on:
 - Belong rail
 - Belong slat tile
 - Open C Cubby with slots
 - Compose slat tile

Note: Snow (TR-FM) plastic trim color is not recommended for use with painted trim colors Plaster (TR- TW) or Chalk (TR-AK). Refer to Very® Seating chainset for Snow.

To Order, Specify:

- 1) Product number.
- 2) Trim color.
 - TR-R Beige
 - TR-1R Brownstone
 - TR-K Charcoal
 - TR-RR Rusty Red
 - TR-FM Snow

Height	Depth	Width	Number	Price
1"(25mm)	4"(102mm)	8"(203mm)	KUSH-0408-H	\$37.62

Work Tools

Belong

Accessory Kit

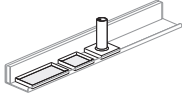

KUAK
Class YA

Features

- Includes one square tray, one rectangular tray and bud vase with square base. All items are plastic.
- Sizes:
 - Square tray: 2.75"(70mm).
 - Rectangular tray: 2.75"(70mm) x 5.5"(140mm).
 - Bud Vase: 4"(102mm) tall, 0.75"(19mm) inside diameter, 2.75"(70mm) square base.
- Designed for use with the Base Tray, Territory Screen or as freestanding pieces.
- Standard in snow trim color.

To Order, Specify:

- 1) Product number.
(No finish specification required)

	Number	Price
	KUAK-0000-BSR	\$210.94

Tool Cup

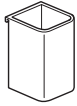

KUTC-0000-H
Class YA

Features

- Includes one plastic tool cup.
- Tool cup mounts on:
 - Belong rail
 - Belong slat tile
 - Open C Cubby with slots
 - Compose slat tile
- Can also be used in freestanding applications.

Note: Snow (TR-FM) plastic trim color is not recommended for use with painted trim colors Plaster (TR-TW) or Chalk (TR-AK). Refer to Very Seating chainset for Snow.

To Order, Specify:

- 1) Product number.
- 2) Trim color.
 - TR-R Beige
 - TR-1R Brownstone
 - TR-K Charcoal
 - TR-RR Rusty Red
 - TR-FM Snow

Height	Depth	Width	Number	Price
3.5"(89mm)	2.5"(64mm)	2.5"(64mm)	KUTC-0000-H	\$37.62

Hanging Sorter

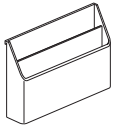

KUHS-0000-H
Class YA

Features

- Includes one hanging sorter with two paper sorters.
- Interior depth of each sorter is 1"(25mm).
- Hanging sorter mounts on:
 - Belong rail
 - Belong slat tile
 - Open C Cubby with slots
 - Compose slat tile

Note: Snow (TR-FM) plastic trim color is not recommended for use with painted trim colors Plaster (TR-TW) or Chalk (TR-AK). Refer to Very Seating chainset for Snow.

To Order, Specify:

- 1) Product number.
- 2) Trim color.
 - TR-R Beige
 - TR-1R Brownstone
 - TR-K Charcoal
 - TR-RR Rusty Red
 - TR-FM Snow

Height	Depth	Width	Number	Price
8.5"(216mm)	2.5"(64mm)	12.75"(324mm)	KUHS-0000-H	\$102.41

Work Tools

Jump Stuff

Paper Sorter

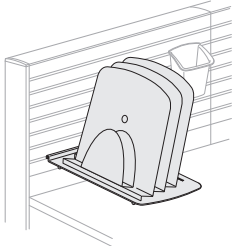

DTPR-3
Class YA

Features

- Includes three dividers, one shelf, and mounting bracket.
- Mounts on slat pad.
- Can also be used as a horizontal freestanding tray.
- Supports maximum of two reams (ten pounds/4.6 kilograms) of paper.

To Order, Specify:

- 1) Product number.
- 2) Translucent trim color.
- 3) Trim color for bracket.

Height	Depth	Width	Number	Trim	
				A	B
9.25"(235mm)	11"(279mm)	9"(229mm)-12"(305mm)	DTPR-3	\$127.91	\$132.39

Binder Bin

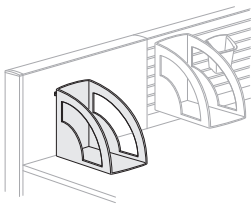

DTSB-3
Class YA

Features

- Mounts on slat pad. Can also be used in freestanding applications.
- Bin accommodates two 3"(76mm) thick binders.

To Order, Specify:

- 1) Product number.
- 2) Translucent trim color.

Height	Depth	Width	Number	Price
12.5"(318mm)	10.5"(267mm)	6.5"(165mm)	DTSB-3	\$96.49

Mini Shelf

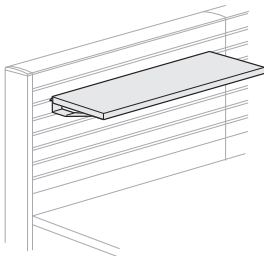

DMSP
Class YA

Features

- Includes high-pressure laminate (HPL) shelf and brackets.
- Mounts on slat pad.
- Shelf thickness 0.75"(19mm)
- Designed for lightweight accessories.

To Order, Specify:

- 1) Product number.
- 2) HPL color.
- 3) Edgeband color.
- 4) Trim color for brackets.

Height	Depth	Width	Number	HPL	
				A	B
1.75"(44mm)	6.25"(159mm)	18"(457mm)	DMSP-18	\$ 196.54	\$212.24
		24"(610mm)	DMSP-24	205.53	221.23

Phone Shelf

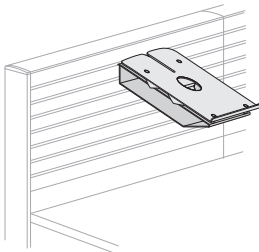

DTPT-3
Class YA

Features

- Includes phone shelf and bracket.
- Mounts on slat pad at 30° angle.
- Supports maximum of two reams (ten pounds/4.6 kilograms) of paper.

To Order, Specify:

- 1) Product number.
- 2) Translucent trim color.
- 3) Trim color for bracket.

Height	Depth	Width	Number	Trim	
				A	B
2.5"(64mm)	11.25"(286mm)	9"(229mm)	DTPT-3	\$185.58	\$190.06

Work Tools

Jump Stuff

Letter Tray

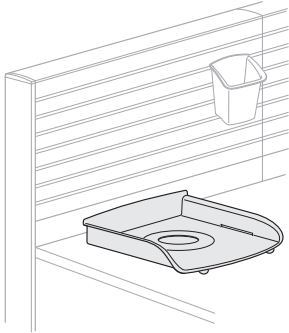

DTLT-2
Class YA

Features

- Used in freestanding applications.

To Order, Specify:

- 1) Product number.
- 2) Translucent trim color.

Height	Depth	Width	Number	Price
2.5"(64mm)	12"(305mm)	10.5"(267mm)	DTLT-2	\$47.15

Waste Bin

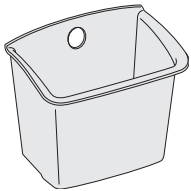

DTRB
Class YA - GSA: Open Market

Features

- Used in freestanding applications.
- Five gallon capacity.

To Order, Specify:

- 1) Product number.
- 2) Translucent trim color.
TR-LQ Frost

Height	Depth	Width	Description	Number	Price
15.5"(394mm)	12"(305mm)	13"(330mm)	Translucent	DTRB-1	\$122.97

Work Tools

Magnetic Accessories

Magnet Hooks

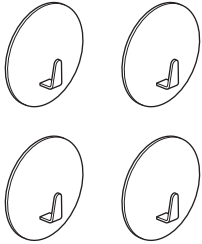

KUAH-0002
Class YA - GSA: Open Market

Features

- Includes four 1.5"(38mm)-diameter magnetic hooks for holding personal items.
- Available in white (not matched to Haworth's color palette).

Specification Tips

- Use on non-textured surfaces for best performance.

To Order, Specify:

- 1) Product number.

Diameter	Number	Price
1.5"(38mm)	KUAH-0002	\$46.39

Magnet Hook



KUAH-0003
Class YA - GSA: Open Market

Features

- Includes one 3"(76mm)-diameter magnetic hook for holding personal items.
- Available in white (not matched to Haworth's color palette).

Specification Tips

- Use on non-textured surfaces for best performance.

To Order, Specify:

- 1) Product number.

Diameter	Number	Price
3"(76mm)	KUAH-0003	\$30.66

Mirror

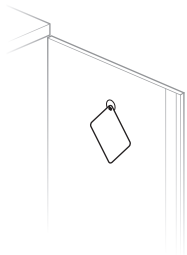

KUAR-0403
Class YA - GSA: Open Market

Features

- Includes one acrylic mirror.
- Can be hung from a Belong magnetic hook.

To Order, Specify:

- 1) Product number.
(No color specification required.)

Actual Width	Actual Length	Number	Price
3.125"(79mm)	4.375"(111mm)	KUAR-0403	\$32.82

Workstation Accessories

Shallow Drawer

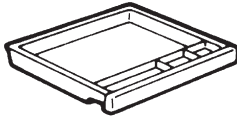

DS-3
Class AA

Features

- Includes one drawer and attachment hardware.
- Shallow drawer has four compartments.
- Drawer does not stack.
- Available in charcoal or gray tone finish colors only.

To Order, Specify:

- 1) Product number.
- 2) Trim color.
 - TR-K Charcoal
 - TR-G Gray Tone

Height	Depth	Width	Number	Price
3"(76mm)	15.375"(391mm)	18.25"(464mm)	DS-3	\$175.60

Steel Center Drawer

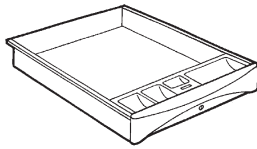

SCD-19
Class MA

Features

- Includes mounting hardware.
- Standard with lock.
- Standard in charcoal finish color only.

To Order, Specify:

- 1) Product number.
(No finish specification required.)

Height	Depth	Width	Number	Price
2"(51mm)	17.5"(445mm)	19.125"(486mm)	SCD-19	\$501.10

Pencil + Drawer

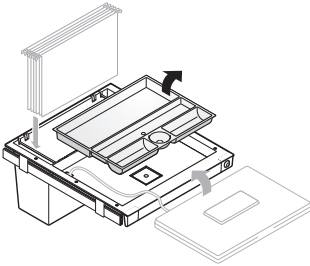
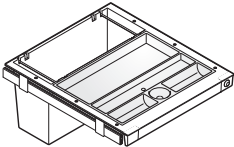

KUDP-2420
Class YA

Features

- Multi-purpose drawer provides organization, hanging filing along with laptop storage.
- Knock-outs at rear of drawer provide electronic charging access while contents are locked.
- Removable organizing tray.
- Thin profile maximizes knee clearance under front of drawer.
- Standard in black trim color with black locks.
- Standard with lock (shipped separately); keyed-alike and master keying options available.

Specification Tips

- To be mounted below worksurfaces 24"(610mm) or deeper.
- **Not for use with 24"(610mm)D knife edge worksurface.**
- Pencil + drawer must be used adjacent to worksurface floor support when specified for use with panel system.

To Order, Specify:

- 1) Product number.
(No finish specification required.)

Height	Depth	Width	Number	Price
11"(279mm)	24"(610mm)	19.5"(495mm)	KUDP-2420	\$624.58

Workstation Accessories

Pencil Drawer

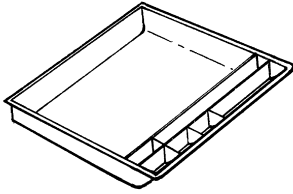

Features

- Includes black plastic drawer, slides, and mounting hardware.
- Attaches under freestanding desks, returns, bridges, system convergent or rectangular worksurfaces.

Specification Tips

- Do not install in area where cantilever bracket is installed.

To Order, Specify:

- 1) Product number.
(No finish specification required.)

Height	Depth	Width	Number	Price
1.625"(41mm)	19"(483mm)	18"(457mm)	JAC-18	\$125.60

JAC-18
Class FP

Make-A-Corner

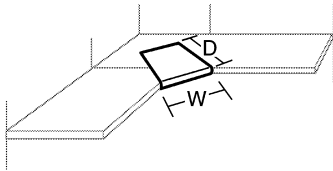

Features

- Creates an angled edge between two (2) perpendicular regular worksurfaces.
- Slides over the top of 1.19"(30mm) thick worksurfaces.
- Accommodates an adjustable keyboard or mouse pad track (screws included).

To Order, Specify:

- 1) Product number.
- 2) Non-metallic trim color.

Depth	Width	Number	Price
21.125"(537mm)	26.125"(660mm)	MAC-0001	\$441.09

MAC-0001
Class AA – GSA: Open Market

Workstation Accessories

Hooks

Compose All-Purpose Hook

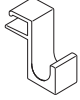

VZAC-0000-P

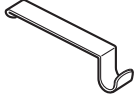

VZAC-0000-H
Class BC

Features

- Includes eight coat hooks.
- (P) For use with full profile aluminum trim.
- (H) For use with thin profile steel trim.

Specification Tips

- Attaches to Compose panel frame or stack frame top with trim.

Note: Not available for use on Glass panels or glass stacks.

To Order, Specify:

- 1) Product number.
- 2) Trim color.

Height	Width	Depth	Number	Trim	
				A	B
1.375"(35mm)	0.5"(13mm)	0.75"(19mm)	VZAC-0000-P	\$582.03	\$605.91
1.375"(35mm)	0.625"(16mm)	3.375"(86mm)	VZAC-0000-H	552.67	576.55

UniGroup All-Purpose Hook

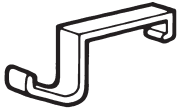

CH-8
Class AA

Features

- Includes eight hooks.
- Attaches to panel steel top cap.
- For use with UniGroup panels only.

To Order, Specify:

- 1) Product number.
- 2) Trim color.

Height	Width	Depth	Number	Price
1"(25mm)	3"(76mm)	0.625"(16mm)	CH-8	\$208.45

UniGroup Too All Purpose Hook



E2CH-8
Class AC

Features

- Includes eight hooks.
- For use with UniGroup Too square painted top cap panels.

To Order, Specify:

- 1) Product number.
- 2) Trim color.

Number	Trim	
	A	B
E2CH-8	\$183.04	\$215.31

Bag Hook

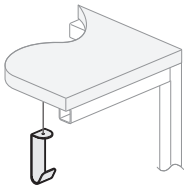

KUWH-0202
Class YA - GSA: Open Market

Features

- Includes one hook and attachment hardware.
- Hook will swivel if plastic washers are installed.

Specification Tips

- Attaches to the bottom of the 1.18"(30mm) and 2"(51mm) thick top.
- Weight Limit 50 lbs max.

To Order, Specify:

- 1) Product number.
- 2) Trim color.

Number	Trim	
	A	B
KUWH-0202	\$65.95	\$74.62

Workstation Accessories

Markerboard Accessories

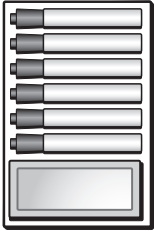

7062-8001

Features

- Recommended dry erase marker products to maintain, clean & condition markerboard laminate.

To Order, Specify:

- 1) Product number
(No finish specification required.)

Description	Number	Price
Dry Erase Marker Kit (holder, six markers and eraser)	7062-8001	\$220.31
Cleaner and Conditioner	7031-7001	263.03
Spray Cleaner	7031-7002	80.29



7031-7002



7031-7001

Workstation Accessories

2/90 Sign Systems

2/90 Sign Systems is a recommended signage program for use with Haworth Systems. Signage options include ADA-compliant panel-mounted name signs, department signs, building directories, in/out boards, restroom and no smoking signs.

For inquiries, catalogs or orders, contact System 2/90 directly at 1-800-777-4310, fax (616) 656-4300, 5350 Corporate Grove Blvd SE, Grand Rapids, MI 49512.

Waste Solutions

Recycling Station

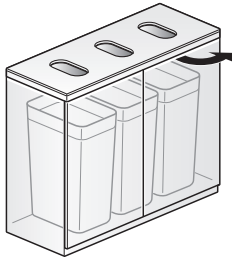

JRPY-3948
Class FM

Features

- Includes:
 - Painted steel cabinet and top with three 11"(279mm) x 6"(152mm) openings.
 - Non-locking hinged doors
 - Clear acrylic overlay for top
 - 3 removable 23 gallon Rubbermaid™ recycle bins
- Acrylic top has specific cleaning requirements. Please follow cleaning guidelines found in Haworth's Care and Maintenance Standards.

To Order, Specify:

- 1) Product number.
- 2) Trim color.

Height	Depth	Width	Number	Trim	
				A	B
39.5"(1003mm)	18.75"(476mm)	48"(1219mm)	JRPY-3948-SJAN	\$6471.68	\$6827.65

Recycling/Trash Bin

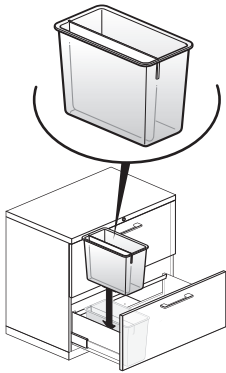

KURB
Class YA

Features

- Includes one plastic bin with removable plastic divider.
- Can be suspended from hanging rails in X Series, Compose and Masters Series pedestals and lateral filing drawers.
- Recycling/Trash Bin can be easily removed from carriage or drawer body to dispose of waste contents.
- Not designed to be freestanding.
- Available in Snow only.
- The removable divider subdivides the space into nominal 4.25"(108mm) and 1.5"(38mm) sections.

Specification Tips

- Cannot accommodate hanging files.

To Order, Specify:

- 1) Product number.
(No finish specification required.)

Nominal Height	Nominal Depth	Nominal Width	Number	Price
9"(229mm)	12.5"(318mm)	6.5"(165mm)	KURB-0912	\$335.20

Lock Programs

Specification Guidelines

Locking Components Shipping Format

Locking components in all Haworth systems, casegoods, files and storage furniture are shipped with the lock housings factory-installed in each unit ready to receive separate lock plug cores. Lock plugs are field installed by means of a control key. Lock plugs and keys will be shipped with random numbering unless they are specified "keyed-alike". Quantity of locks will match quantity required for locking components on the order.

HW Lock Program

All HW lock plugs and keys will be standard in a Master Lock Program. A Master Lock program allows for better management of the facility where one "Master Key" can be used by Facility Management to service all locking components within a facility. Individual offices can be keyed-alike and will receive single-key access specific to the locking components within that workstation. Multiple locks in credenza components should be keyed-alike for the convenience of single-key access. General storage or file areas may also be keyed-alike so that individuals may have access to shared department documents or supplies.

To order new products within a workstation keyed-alike, the specifier should select the number of locks within the workstation and specify LSET quantities through Orderline. CSET lock plug and keys are to key-alike existing product for reconfigurations.

On Site Lock Installation

One Control Key for installing the lock plug will be included with each incremental order unit of up to 200 locks. The control key is used to insert and remove the lock plug into the housing at the installation site. The control key cannot be used to remove a lock plug in the locked position from its housing. Additional control keys are available and should be considered for the convenience of installing locks in widely separated areas of a facility (see Keys Only, page 81).

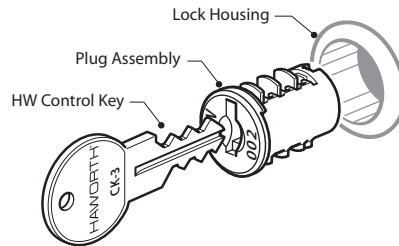

Replacement Lock Plugs and Keys

To order replacement lock plugs and keys, use the appropriate service parts catalog number or CSETS.

Coding the Office Plan

Each lock location should be identified graphically on the plan by a dash mark. Encode your office floor plan by using your own coding system to identify each workstation or area that requires keyed-alike locks. Remember that some furniture will have more than one lock — a double pedestal desk, for instance. The coded floor plan with office identification numbers and lock quantities and color code will be required at the time of installation. The installer will be responsible for assignment of lock quantities based on this plan.

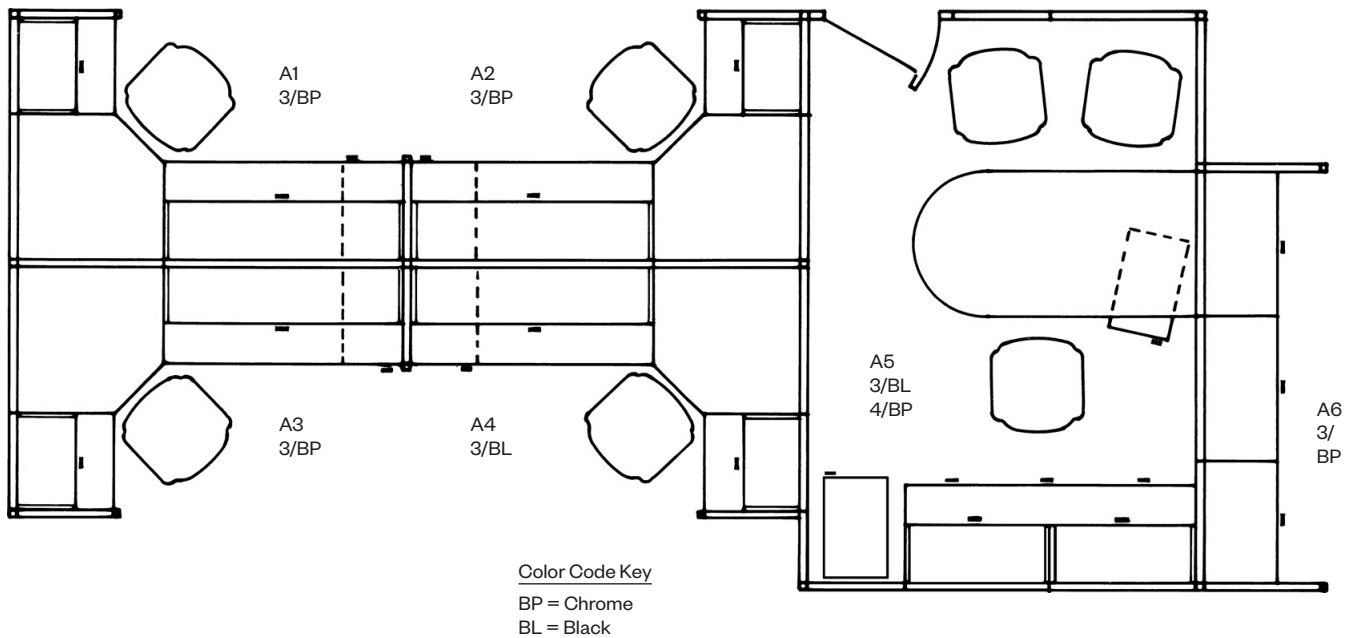

Lock Programs

HW Lock Program

HW Lock Program The Haworth HW Lock Program is a Master Lock Program and offers the option to have workstations keyed-alike with 300 lock numbers. LSET keyed-alike lock plugs/keys are for new locking product orders only and are available at no charge.

For reconfiguration projects, there are CSET lock plugs and keys available at a nominal charge.

Work Sheet Preparation Photocopy the HW Lock Work Sheet to assist in specifying locks. This work sheet is for your convenience and is not to be submitted with your purchase order.

Using the Coded Office Plan Enter the workstation or area identification codes from the plan into the columns headed OFFICE NUMBER on the HW Lock work sheet. The work sheet can accommodate 100 location entries.

Specifying Keyed-Alike Lock Quantities and Colors Using the plan, count the number of locking components in each workstation. Enter the number of locks under "QUANTITY" columns, taking into account the chrome or black finish, depending on lock finishes offered. When completed, each workstation should be assigned a quantity of LSETs. For file banks or storage areas requiring a larger quantity of the same lock numbers, specify LSET-999.

NO KEYED-ALIKE NOTE:
 When no LSETS are specified, plugs and keys for the total number of locking components will be shipped automatically.

A Master Key will need to be separately specified.

Example:

Office Number	Quantity		LSET Number	Totals	
	Chrome	Black		Chrome	Black
A1	3		LSET-3	1	
A2	3		LSET-3	1	
A3	3		LSET-3	1	
A4		3	LSET-3		1
A5	4	3	LSET-3		1
			LSET-4	1	
A6	3		LSET-3	1	

Total the number of LSET quantities at the bottom of the work sheet. Transfer each total quantity to your Orderline or written purchase order.

When specifying Keyed-Alike (LSETS): LSETS must be ordered for the total number of locking components. Only the quantity of LSETS ordered will be shipped. We do not ship based upon number of locking components on order.

LSETS ordered in excess of quantities required for new locking product on the order may result in the order being placed on hold.

As a final verification of quantity, review the plan carefully to be sure that all products with locks have been identified. Remember that desks, credenzas and storage units may have multiple locking components.

Line Item Entry Transfer the data from the work sheet to your Orderline or written purchase order. Enter the appropriate LSET catalog numbers on your order, followed by finish option code -BP or -BL.

Example:

Quantity	Description
4	LSET-3, LR-BP
1	LSET-4, LR-BL
2	LSET-3, LR-BL

Order Processing and Packing Method Haworth will assign the lock numbers for all keyed-alike orders. Note: Specific key numbers cannot be requested.

Upon receipt of your keyed-alike order, Haworth will draw from our standard inventory of 300 lock numbers. Lock plugs will be shipped according to finish in sets per the quantity specified. HW locks and keys (Figure 3) will carry a stamped "HW" on one side with 1 through 300 on the other side as an indication of the "HW lock" program.

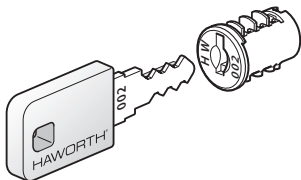

Figure 3.

Order Changes For Order Changes/Cancellations; refer to North American Terms of Sale.

Lock Programs

HW Lock Plugs and Key

HW Lock Plugs and Keys

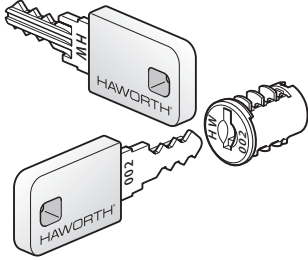

LSET
Class HA – GSA: Open Mktet

Features

- The Haworth HW Lock Program offers 300 lock numbers. LSET keyed-alike lock plugs/keys are for new locking product orders only and are available at no charge. LSET's ordered in excess of quantities required for new locking product on the order may result in order being placed on hold.
- For reconfiguration projects there are CSET lock plugs and keys available at a nominal charge.
- All lock plugs and keys with one LSET/CSET will ship with the same key number which is chosen at random.
- LSET-999 and CSET-999 are for quantities greater than 30 lock plugs and keys. Specify quantity of locks; locks are priced "per piece". Numbers will be the same for all locks and chosen at random.
- Haworth will assign key numbers from the inventory of 1 through 300.
- To order specific key numbers for replacement; refer to page 81.
- Master key available; separately specified.
- Keys are standard in nickel with black overmolded head; Locks plugs are available in chrome and black finishes.

To Order LSET, Specify:

- 1) Product number.
- 2) Lock plug finish color.
LX-BP Chrome
LX-BL Black

To Order CSET, Specify:

- 1) Product number.
- 2) Lock plug finish color.
LR-BP Chrome
LR-BL Black

Description	Number	Price
Order with new product orders only*		
1 Lock Plug and Key	LSET-1	N/C
2 Lock Plugs and Keys	LSET-2	N/C
3 Lock Plugs and Keys	LSET-3	N/C
4 Lock Plugs and Keys	LSET-4	N/C
5 Lock Plugs and Keys	LSET-5	N/C
6 Lock Plugs and Keys	LSET-6	N/C
7 Lock Plugs and Keys	LSET-7	N/C
8 Lock Plugs and Keys	LSET-8	N/C
9 Lock Plugs and Keys	LSET-9	N/C
10 Lock Plugs and Keys	LSET-10	N/C
11 Lock Plugs and Keys	LSET-11	N/C
12 Lock Plugs and Keys	LSET-12	N/C
30 Lock Plugs and Keys	LSET-30	N/C
Key all locks alike (quantities greater than 30)	LSET-999	N/C
Order for reconfiguration of existing product		
1 Lock Plug and Key	CSET-1	\$ 14.99
2 Lock Plugs and Keys	CSET-2	29.98
3 Lock Plugs and Keys	CSET-3	44.97
4 Lock Plugs and Keys	CSET-4	59.96
5 Lock Plugs and Keys	CSET-5	74.95
6 Lock Plugs and Keys	CSET-6	89.94
7 Lock Plugs and Keys	CSET-7	104.93
8 Lock Plugs and Keys	CSET-8	119.92
9 Lock Plugs and Keys	CSET-9	134.91
12 Lock Plugs and Keys	CSET-12	179.88
30 Lock Plugs and Keys	CSET-30	449.70
Key all locks alike (quantities greater than 30)	CSET-999	14.99

Lock Programs

Keys

HW Plugs and Keys

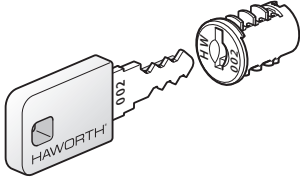

HW-SVC
Class HA – GSA: Open Market

Features

- Includes one lock plug and one key.
- Keys are standard in nickel with black overmolded head.
- Lock plugs are available in chrome or black finishes.
- One control key (CK-3) for installing lock plugs into lock housings is provided.
- The key number will print on one side of key and HW on other side.
- Lock plug will also show HW and key number (refer to illustrations).

To Order, Specify:

- 1) Product number.
- 2) Lock plug finish color.
LR-BP Chrome
LR-BL Black
- 3) Key number.

Key Number Selection	Number	Price
KY-001 through KY-300	HW-SVC	\$28.68

HW Replacement Keys

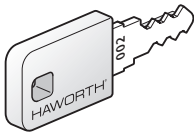

HWSK
Class HA – GSA: Open Market

Features

- Includes HW keys only.
- HWSK-1; order for specific HW key number replacement; Specify HW key number.
- HWSK-2 through HWSK-300; specific HW key number series included.

To Order, Specify:

- 1) Product number.
- 2) Key number (HWSK-1 only).
(No finish specification required.)

Description	Quantity Included	Key Numbers Included	Number	Price
Includes one HW key; specify key number/quantity	1		HWSK-1	\$ 22.72
	50	1-50	HWSK-2	\$ 383.02
	50	51-100	HWSK-3	383.02
	50	101-150	HWSK-4	383.02
	50	151-200	HWSK-5	383.02
	50	201-250	HWSK-6	383.02
	50	251-300	HWSK-7	383.02
	300	1-300	HWSK-300	2033.66

HW Master Key

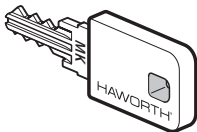

HWMK-1
Class HA – GSA: Open Market

Features

- Includes one key.
- HWMK keys are silver with a red overmolded head.

Note: Master keys can only be used for HW Lock Program.

To Order, Specify:

- 1) Product number.
(No finish specification required.)

Description	Number	Price
Master key	HWMK-1	\$24.77

HW Control Key



CK-3
Class HA – GSA: Open Market

Features

- A single control key is provided with each lock shipment.
- CK-3 control key can be used to remove HW lock plug in unlocked position only.

To Order, Specify:

- 1) Product number.
(No finish specification required.)

Description	Number	Price
Control key (no key number selection required)	CK-3	\$24.77

HW Key Blank

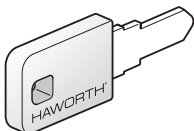

HWKB-1
Class HA – GSA: Open Market

Features

- Includes 100 key blanks for use with HW Lock Program only.

To Order, Specify:

- 1) Product number.
(No finish specification required.)

Description	Number	Price
Key Blank	HWKB-1	\$562.06

Lock Programs

Digital Locks

Digital Lock

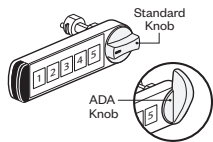

HUDR-R

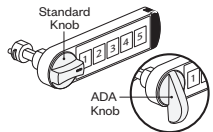

HUDR-L

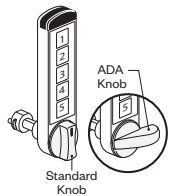

HUDR-B

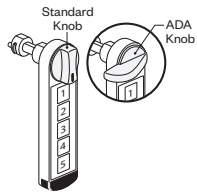

HUDR-T

Class HA – GSA: Open Market

Features

- Includes:
 - Digital lock with 5-digit horizontal or vertical keypad and rotating lock knob with 180° rotation.
 - Classic lock uses CR-2032 3-volt lithium battery.
 - Max lock uses CR-2450 3-volt lithium battery.
 - Factory-assigned access code
- Standard and ADA-compliant knob versions are available.
- Fits standard lock housings in all Haworth systems, casegoods, files and storage furniture.
- Two software versions allow the lock to be programmed by individual users each time it's used, or by a facility manager for workstations where re-programming is infrequent.
- Master codes can be created by facilities management to override factory-assigned access codes.
- Factory or master codes provide manager access and enable re-programming.
- Available in black or brushed chrome.

Specification Tips

- Classic lock has a typical battery life of 3-5 years (based on length of usage).
- Max lock has a typical battery life of 10+ years (based on length of usage).
- Optional control key fob can be specified separately to manage factory and/or master codes.
- User-Programmable (Locker Mode) user programs and codes into lock with each use.
- Facility- Programmed (Station Mode) code programmed for user, same code each use.
- Refer to application matrix for appropriate usage.

To Order, Specify:

1) Product number, including:

1 Keypad Orientation

- L** Horizontal, knob left
- R** Horizontal, knob right
- T** Vertical, knob top
- B** Vertical, knob bottom

2 Software Option

- U** User-programmable (Locker Mode)
- F** Facility-programmed (Station Mode)

2) Trim color for lock

Description	Length	Width	Height	Number		Price
				1	2	
Standard Knob						
Classic	3.86"(98mm)	1"(25mm)	0.75"(19mm)	HUDR- [] 180- [] Y		\$544.00
Max	4.01"(102mm)	1.12"(28mm)	0.80"(20mm)	HUDM- [] 180- [] N		659.00
ADA Knob						
Classic	3.86"(98mm)	1"(25mm)	0.96"(24mm)	HUDR- [] 180- [] YA		\$594.00
Max	4.01"(102mm)	1.12"(28mm)	1.02"(26mm)	HUDM- [] 180- [] NA		709.00

Digital Lock Control Key Fob



HUDF-F

Class HA – GSA: Open Market

Features

- Includes one control key fob and CR2032 3-volt lithium battery.
- Provides facility management of factory, master, and user codes, allowing management access and re-programming of digital locks (HUDR/HUDM).
- Stores an unlimited number of factory and master codes.

Specification Tips

- Each lock must be programmed to accept key fob before use.
- Works with both Classic and Max digital locks.

To Order, Specify:

1) Product number.

	Number	Price
	HUDF-F	\$828.16

Lock Programs

Digital Lock Applications

	Lock Location	Knob Top	Knob Bottom	Knob Left	Knob Right
Adaptable Overhead Storage Unit					
Flipper & Single Slider			•	•	•
Hinge			•	•	
Be_Hold Accessory Drawer					
Steel Drawer Front	Lower Right of Drawer Front				•
Be_Hold Stationary Pedestals					
12"W w/Steel Drawer	Lower Right of Top Drawer				•
12"W w/Hinged Door on LH Side (LH Unit)	Upper Right of Door Front	•			•
12"W w/Hinged Door on RH Side (RH Unit)	Upper Left of Door Front	•		•	
Box/File & Box/Box/File	Upper Right of Top Drawer	•			Q, W
File/File	Upper Right of Top Drawer	•			•
Be_Hold Suspended Pedestal					
w/Steel Drawer	Lower Right of Top Drawer				•
Door on LH Side (LH Unit)	Upper Right of Door Front	•			•
Door on RH Side (RH Unit)	Upper Left of Door Front	•		•	
Be_Hold Mobile Pedestal					
12"W w/Steel Drawer	Lower Right of Top Drawer				•
12"W w/Hinged Door on LH Side (LH Unit)	Upper Right of Door Front	•			•
12"W w/Hinged Door on RH Side (RH Unit)	Upper Left of Door Front	•		•	
Box/File & Box/Box/File	Upper Right of Top Drawer	•			Q, W
File/File	Upper Right of Top Drawer	•			•
Be_Hold Stationary Lateral Files					
1.5H, 2H, 3H	Upper Right of Top Drawer	•			•
Be_Hold Storage Cabinet					
1.5H Double Door	Upper Left of RH Door Front	N, W		•	
2H, & 3H Double Door	Upper Left of RH Door Front	•		•	
1.5H Door on LH Side (LH Unit)	Upper Right of Door Front	N, W			•
2H, & 3H Door on LH Side (LH Unit)	Upper Right of Door Front	•			•
1.5H Door on RH Side (RH Unit)	Upper Left of Door Front	N, W		•	
2H, & 3H Door on RH Side (RH Unit)	Upper Left of Door Front	•		•	
Double Door 48.5	Middle Left of RH Door Front	N, W	•	•	
Double Door 57.5/65.5/73.5	Middle Left of RH Door Front	•	N, W	•	
Double Door 81.5	Middle Left of RH Door Front	•	•	•	
Door on RH Side (RH Unit) 48.5	Middle Left of Door Front	N, W	•	•	
Door on LH Side (LH Unit) 48.5	Middle Right of Door Front	N, W	•		•
Door on RH Side (RH Unit) 57.5/65.5/73.5	Middle Left of Door Front	•	N, W	•	
Door on LH Side (LH Unit) 57.5/65.5/73.5	Middle Right of Door Front	•	N, W		•
Door on RH Side (RH Unit) 81.5	Middle Left of Door Front	•	•	•	
Door on LH Side (LH Unit) 81.5	Middle Right of Door Front	•	•		•
Be_Hold Credenza Units with Drawers					
1.5H, 2H	Upper Right of Top Drawer	•			•
Be_Hold Sliding Credenza Units with Sliding Doors					
1.5H, 2H, & 3H	not available				
Be_Hold Overhead Storage Units					
Hinged Doors	Lower Left of RH Door Front		•	•	
Sliding Doors	not available				

Pull Options	
K	Aluminum, HPL & Wood J-Pull
B	Bar
Q	Blade
9	Classic
7	Crescent
1	Ellipse
L	Full Pull
8,P	Linear

Pull Options	
N	No Pull
5	Standard
J	Steel J-Pull
2	Radius
3	Taper
W	Wing
F	Wood Finger Pull

Lock Programs

Digital Lock Applications

	Lock Location	Knob Top	Knob Bottom	Knob Left	Knob Right
Be_Hold Stack Storage Cabinet					
Double Door	Bottom Left of RH Door Front		•	•	
Door on LH Side (LH Unit)	Bottom Right of Door Front		•		•
Door on RH Side (RH Unit)	Bottom Left of Door Front		•	•	
Be_Hold Personal Storage Tower					
3H Storage Door on RH Unit	Upper LH of Storage Door Front	N, W			•
3H Storage Door on LH Unit	Upper RH of Storage Door Front	N, W		•	
4H, 5H, & 6H Storage Door on RH Unit	Upper LH of Storage Door Front	•		•	
4H, 5H, & 6H Storage Door on LH Unit	Upper RH of Storage Door Front	•		•	
Ped Drawer Box/Box/File	Upper Right of Top Drawer	•			Q, W
Ped Drawer File/File	Upper Right of Top Drawer	•			•
Be_Hold Personal Storage Tower w/Valet Door					
3H Valet Door on LH Side	Upper RH of Valet Door Front	N, W			•
3H Valet Door on RH Side	Upper LH of Valet Door Front	N, W		•	
4H, 5H, & 6H Valet Door on LH Side	Upper RH of Valet Door Front	•			•
4H, 5H, & 6H Valet Door on RH Side	Upper LH of Valet Door Front	•		•	
Ped Drawer Box/Box/File	Upper Right of Top Drawer	•			Q, W
Ped Drawer File/File	Upper Right of Top Drawer	•			•
Be_Hold Wardrobe					
Door on RH Unit 41.5	Upper LH of Door Front	N, W		•	
Door on LH Unit 41.5	Upper RH of Door Front	N, W			•
Door on RH Unit 48.5	Mid LH of Door Front	N, W	•	•	
Door on LH Unit 48.5	Mid RH of Door Front	N, W	•		•
Door on RH Unit 57.5/65.5	Mid LH of Door Front	•	N, W	•	
Door on LH Unit 57.5/65.5	Mid RH of Door Front	•	N, W		•
Belong					
Security Drawer	Drawer Front				•
Beside Pantry					
Pantry Door, Left Side	Top Right	•			
Pantry Door, Right Side	Top Left	•			
Compose Storage Lower Storage-Mobile Pedestals					
1.5H, 2H	Top Right	7, 8, 9, P			7, 8, P
Compose Pedestal					
1H, 1.5H, 2H	Top Right	7, 8, 9, P			7, 8, P
Compose Lateral Files					
1H	not available				
1.5H, 2H, 3H	Top Right	7, 8, 9, P			7, 8, 9, P
Compose Open Shelf Lateral Files					
1.5H, 2H	not available				

Note: Digital locks are not compatible with the Aluminum J Pull (K) on Compose.

Pull Options	
K	Aluminum, HPL & Wood J-Pull
B	Bar
Q	Blade
9	Classic
7	Crescent
1	Ellipse
L	Full Pull
8, P	Linear

Pull Options	
N	No Pull
5	Standard
J	Steel J-Pull
2	Radius
3	Taper
W	Wing
F	Wood Finger Pull

Lock Programs

Digital Lock Applications

	Lock Location	Knob Top	Knob Bottom	Knob Left	Knob Right
Compose Combination Units					
2H Left-Hand/Right-Hand	Top Right	7, 8, 9, P			7, 8, 9, P
Compose Storage Units w/Doors					
1H, 2H, 3H	Top Left Corner of Right Door	7, 8, 9, P		7, 8, 9, P	
Compose Personal Storage Tower w/Side Bookcase					
Right-Hand/Left-Hand	Top Right of BBF	7, 8, 9, P			7, 8, P
Compose Personal Storage Tower w/Wardrobe — One Unit					
RH Wardrobe - Wardrobe Door	Left Edge of Door	7, 8, 9, P	7, 8, 9, P	7, 8, 9, P	
RH Wardrobe - Storage Door	Bottom Right Corner of Door		7, 8, 9, P		7, 8, 9, P
RH Wardrobe - BBF	Top Right of BBF	7, 8, 9, P			7, 8, P
LH Wardrobe - Wardrobe Door	Right Edge of Door	7, 8, 9, P	7, 8, 9, P		7, 8, 9, P
LH Wardrobe - Storage Door	Bottom Left Corner of Door		7, 8, 9, P	7, 8, 9, P	
LH Wardrobe - BBF	Top Right of BBF	7, 8, 9, P			7, 8, P
Compose Wardrobes					
Wardrobe - Right		7, 8, 9, P	7, 8, 9, P	7, 8, 9, P	
Wardrobe - Left		7, 8, 9, P	7, 8, 9, P		7, 8, 9, P
Compose Full Height Doors Stack-on Storage					
Base Unit (1H, 2H)	Lower Left Corner of Right Door		7, 8, 9, P	7, 8, 9, P	
Compose Partial Height Doors Stack-On Storage					
Base Unit (1H, 2H)	Lower Left Corner of Right Door		7, 8, 9, P	7, 8, 9, P	
Masters Lower Storage Pedestals & Attached Lateral Files					
Attached & Mobile Pedestal	Upper Right Drawer Front	•			•
Attached Lateral File (1H, 1.5H & 2H)	Upper Right Drawer Front	•			•
Masters Freestanding Lateral Files (3H, 4H, 5H & 6H)					
Freestanding Lateral File (Drawer 3H, 4H, 5H & 6H)	Upper Right Drawer Front (2nd Drawer from Bottom)	•			•
Freestanding Lateral File (Upper Doors 5H & 6H only)	Lower Left of RH Door Front		•	•	
Masters Lower 2-door Storage					
2H Lower Storage	Upper Left of RH Door Front	•		•	
3H Lower Storage	Middle Left of RH Door Front	•	•	•	
Masters Combination Units					
Doors	Lower Left of RH Door Front		•	•	
Drawers	Upper Right of Top Drawer Front	•			•
Masters Wardrobe with Open Storage					
Door on LH Side (LH Unit)	Lower Mid RH of Door Front	•	•		•
Door on RH Side (RH Unit)	Lower Mid LH of Door Front	•	•	•	
Masters Wardrobe with Closed Storage					
2-Door Unit	Lower Mid of RH Door Front	•	•	•	
Masters Personal Storage Tower with F/F/F & V					
Valet Door on LH Side	Lower Mid RH of Door Front	•	•		•
Valet Door on RH Side	Middle Left of Door Front	•	•	•	
Storage Door on RH Side	Lower LH of Door Front		•	•	
Storage Door on LH Side	Lower RH of Door Front		•		•
Ped Drawer (The Same Regardless of LH or RH Unit)	Upper Right of Middle Drawer	•			•

Pull Options	
K	Aluminum, HPL & Wood J-Pull
B	Bar
Q	Blade
9	Classic
7	Crescent
1	Ellipse
L	Full Pull
8,P	Linear

Pull Options	
N	No Pull
5	Standard
J	Steel J-Pull
2	Radius
3	Taper
W	Wing
F	Wood Finger Pull

Lock Programs

Digital Lock Applications

	Lock Location	Knob Top	Knob Bottom	Knob Left	Knob Right
Masters Personal Storage Tower with F/F & Valet					
Valet Door on LH Side	Middle Right of Door Front	•	•		•
Valet Door on RH Side	Middle Left of Door Front	•	•	•	
Storage Door on RH Side	Lower LH of Door Front		•	•	
Storage Door on LH Side	Lower RH of Door Front		•		•
Ped Drawer (The Same Regardless of LH or RH Unit)	Upper Right of Top Drawer	•			•
Masters Storage Tower					
Storage Door on RH Unit	Lower LH of Door Front		•	•	
Storage Door on LH Unit	Lower RH of Door Front		•		•
Ped Drawer (The Same Regardless of LH or RH Unit)	Upper Right of Top Drawer	•			•
Masters Freestanding Wardrobe Tower					
Door on RH Unit	Lower Mid LH of Door Front	•	•	•	
Door on LH Unit	Lower Mid RH of Door Front	•	•		•
Masters Credenza Units					
Pedestals or Lateral Files	Upper Right of Top Drawer	•			•
Closed Storage Units	Upper Left of RH Door Front	•		•	
Masters Upper Storage					
Vertical Storage Units	Lower Left of RH Door Front		•	•	
Overhead Storage Units	Lower Left of RH Door Front		•	•	
X Series					
Attached, Suspended, Mobile Pedestals*	Lockbar, Right-Hand				•
	Lockbar, Left-Hand (individually locking only)			•	
Personal Storage Tower (2H and 3H only)	Top of Tower			•	•
Personal Storage Tower Pedestal Section	Lockbar, Right-Hand				•
	Lockbar, Left-Hand (individually locking only)			•	
Personal Storage Tower Valet Section	Valet Door, Right-Hand	•	•	•	
	Valet Door, Left-Hand	•	•		•
Personal Storage Tower Storage Unit Section	Storage Door, Left-Hand	•	•		•
	Storage Door, Right-Hand	•	•	•	
Locker, Group Locker, Cubby Locker	Left-Hand Door	•	•		•
	Right-Hand Door	•	•	•	
Lateral File*	Top of File			•	•
	Drawer Front	•		•	•
Combination Unit Drawer Section	Top of Unit			•	•
Combination Unit Storage Unit Section	Storage Door, Left-Hand	•	•		•
	Storage Door, Right-Hand	•	•	•	
Combination Unit Valet Section	Valet Door, Left-Hand	•	•		•
	Valet Door, Right-Hand	•	•	•	
Storage Cabinet and Wardrobe	Top of Cabinet			•	•
	Right-Hand Door	•	•	•	

* Items not available with the ADA knob.

Pull Options	
K	Aluminum, HPL & Wood J-Pull
B	Bar
Q	Blade
9	Classic
7	Crescent
1	Ellipse
L	Full Pull
8,P	Linear

Pull Options	
N	No Pull
5	Standard
J	Steel J-Pull
2	Radius
3	Taper
W	Wing
F	Wood Finger Pull

Lock Programs

Service Parts

Service Parts

Service parts for the SL, ML and MLP are available through www.EasyKeys.com; Haworth will not be supplying these products directly.

To order products, dealers must set up an account with Easy Keys.

Easy Key is offering discounts to Haworth dealers. To set-up an account, use the link provided on My Haworth - search Easy Keys.

After the account is set up, dealers can order product at the negotiated rate. For future orders, dealers can go directly to www.EasyKeys.com and log in. In order to receive the discounted pricing, dealers must log in with the username and password that was created while setting up the account.

Accessories Resources

Surfaces Materials

Index

Warranty

Surface Materials

Finish Color Legend

Trim

Grade A

Smooth

TR-R	Beige
TR-AK	Chalk
TR-K	Charcoal
TR-C1	Cocoa
TR-J	Graphite
TR-G	Gray Tone
TR-AA	Putty
TR-E	Smoke
TR-PLS	Smooth Plaster
TR-FM	Snow

Textured

TR-TG	Grout
TR-TF	Pitch
TR-TW	Plaster

Translucents

TR-LQ	Frost
TR-LX	Ice
TR-LY	Moon
TR-LU	Shadown

Grade B

Smooth

TR-1C	Accent Blue
TR-1E	Accent Orange
TR-1G	Blue Jay
TR-1R	Brownstone
TR-1N	Night
TR-1Q	Park
TR-RR	Rusty Red
TR-1M	Sable
TR-1J	Sky Blue
TR-1K	Wren

Smooth Metallic

TR-DM	Dark Bronze Metallic
TR-MC	Metallic Champagne
TR-MG	Metallic Gunmetal
TR-LE	Metallic Silver

Textured Metallic

TR-AR	Argent
TR-HE	Hellenic

Lock Plugs

LR-BL	Black
LR-BP	Chrome

Laminate

Grade A

Solid Color

H-34	Beige
H-AK	Chalk
H-8J	Charcoal
H-3J	Graphite
H-62	Gray Tone
H-WL	Linen
H-3P	Platinum
H-AA	Putty
H-3E	Smoke

Patterned

H-P1	Linen Casual
H-P2	Linen Classic
H-P3	Linen Crisp
H-P4	Linen Flax

Wood Grain

H-B06	Brazilwood
H-E79	Colombian Walnut
H-DYP	New Age Oak
H-AE	Maple
H-E15	River Cherry
H-C09	Williamsburg Cherry

Grade B

Premium Wood Grain

H-C8	Blonde Modern Cherry
H-D1	Daintree
H-KP	Field Elm
H-KN	Grey Elm
H-KM	Landmark Wood
H-D2	Mocha Modern Cherry
H-KL	Neo Walnut
H-KR	Phantom Ecrú
H-KS	Phantom Pearl
H-C9	Spiced Modern Cherry

Edgeband

Solid Color

HP-34	Beige
HP-AK	Chalk
HP-8J	Charcoal
HP-3J	Graphite
HP-62	Gray Tone
HP-WL	Linen
HP-3P	Platinum
HP-AA	Putty
HP-3E	Smoke

Patterned Edgeband

HP-P1	Linen Casual
HP-P2	Linen Classic
HP-P3	Linen Crisp
HP-P4	Linen Flax

Wood Grain

HP-C8	Blonde Modern Cherry
HP-B06	Brazilwood
HP-E79	Colombian Walnut
HP-D1	Daintree
HP-KP	Field Elm
HP-KN	Grey Elm
HP-KM	Landmark Wood
HP-AE	Maple
HP-D2	Mocha Modern Cherry
HP-KL	Neo Walnut
HP-DYP	New Age Oak
HP-KR	Phantom Ecrú
HP-KS	Phantom Pearl
HP-E15	River Cherry
HP-C9	Spiced Modern Cherry
HP-C09	Williamsburg Cherry

Planked Wood

VH-W35	Walnut
VB-W35	White Oak

Painted MDF

PW-F	Black
PW-PL	Polar
PW-SY	Stormy
PW-VA	Vapor

ALERT: These materials are current, however they are being considered for future obsolescence due to low volume.

Trim

TR-1F	Accent Red
TR-CTS	Chartreuse
TR-1H	Terra

Laminate

H-AM	Amber Cherry
H-AD	Medium Cherry

Edgeband

HP-AM	Amber Cherry
HP-AD	Medium Cherry

Surface Materials

Fabrics/Color Legend

Seating Fabrics

Grade A

- (4H) Blanket
- (3J) Hobson
- (4J) Morse
- (3L) Novelty
- (2A) Pixel
- (3A) Tellure

Grade B

- (4N) Diagonale
- (4Z) Element
- (S6E) Floyd by Kvadrat
- (S4) Kaleidoscope
- (4V) Ramie
- (S8) Reflect by Kvadrat
- (MV) Tech

Grade C

- (6K) Dots
- (4T) Oceanic
- (3S) Scapes

Grade D

- (LW) Atlas by Kvadrat
- (4D) Big Arrow
- (1K) Big Diagonale
- (NV) Clara 2 by Kvadrat
- (JB) Cotswold
- (6M) Main Line Flax
- (S7) Melange Nap by Kvadrat
- (RP) Recheck by Kvadrat

Grade E

- (SY) Steelcut Trio 3 by Kvadrat

Grade F

- (SV) Divina Melange 3 by Kvadrat
- (SZ) Hallingdal 65 by Kvadrat

* For most current finish and fabric availability please reference surfaces.haworth.com.

ALERT: These materials are current, however they are being considered for future obsolescence due to low volume.

Seating Fabrics

Grade A
(MM) Twist

Grade B
(1X) Gauge

Haworth+

For information on the Haworth+ alliance program, including images and product availability, please refer to: [Haworth.com](https://www.haworth.com) > Surface Collection > Haworth+ Library

Customer's OwnMaterial (COM)

For general Customer's Own Material (COM) information including processes and forms, please refer to:

[Haworth.com](https://www.haworth.com) > Surface Collection > Resources > COM

For information on approved COM's, please refer to:

[Haworth.com](https://www.haworth.com) > Surface Collection > COM Library

Index

Products are listed alphabetically in this index by alpha-numeric prefix/suffix codes.

Product Code	Product Description	Page
169BK	Ergotron Keyboard Tray — Keyboard Tray with Mouse Pad	43
24-205-214	Ergotron Laptop Cart — Neo-Flex	41
24-214-085	Ergotron Mobile Cart — WorkFit-C	39
24-215-085	Ergotron Mobile Cart — WorkFit-C	39
24-216-085	Ergotron Mobile Cart — WorkFit-C	39
24-220-055	Ergotron Mobile Digital Workspace — Teachwell®	42
24-312-026	Ergotron Sit-Stand Workstation — WorkFit A — Dual Attached	29
24-392-026	Ergotron Sit-Stand Workstation — WorkFit A — Dual Attached	29
24-481-003	Ergotron Mobile Cart — LearnFit — LearnFit Desk	40
24-547-003	Ergotron Mobile Cart — LearnFit — LearnFit Desk	40
33-341-200	Ergotron Sit-Stand Workstation — WorkFit-S — Dual Attached	30
33-349-200	Ergotron Sit-Stand Workstation — WorkFit-S — Dual Attached	30
33-349-211	Ergotron Sit-Stand Workstation — WorkFit-S — Dual Attached	30
33-350-200	Ergotron Sit-Stand Workstation — WorkFit-S — Single Attached	30
33-397-085	Ergotron Sit-Stand Workstation — WorkFit-T — Desktop	31
33-406-085	Ergotron Sit-Stand Workstation — WorkFit-TL — Desktop	32
33-418-085	Ergotron Sit-Stand Workstation — WorkFit-TL — Desktop	32
33-458-917	Ergotron Sit-Stand Workstation — WorkFit-Z Mini	33
33-467-921	Ergotron Standing Workstation — WorkFit-TX	34
33-468-921	Ergotron Standing Workstation — WorkFit Corner	35
45-214-026	Ergotron Monitor Arms — MX — Desk Mount - Single Arm	20
45-228-026	Ergotron Monitor Arms — MX — Wall Mount - Heavy Duty	20
45-475	Ergotron Monitor Arms — HX Desk Mount — Single Arm	23
45-476	Ergotron Monitor Arms — HX Desk Mount — Dual Arm	23
45-478	Ergotron Monitor Arms — HX Desk Mount — Single Arm	23
45-486	Ergotron Monitor Arms — MXV Desk Mount — Single Arm	21
45-496	Ergotron Monitor Arms — MXV Desk Mount — Dual Arm	21
47-109-224	Ergotron Monitor Mount — TRACE Accessories — Single Conversion Kit	28
47-110-224	Ergotron Monitor Mount — TRACE Accessories — Dual Conversion Kit	28
60-589-060	Ergotron Monitor Arms — Accessories — Monitor Quick Release LCD Bracket	25
7031-7001	Workstation Accessories — Markerboard Accessories	74
7031-7002	Workstation Accessories — Markerboard Accessories	74
7062-8001	Workstation Accessories — Markerboard Accessories	74
80-063-216	Ergotron CPU Holder — Small CPU Holder	44
80-105-064	Ergotron CPU Holder — Cable CPU Holder	44
97-468-202	Ergotron CPU Holder — Universal CPU Holder	44
97-468-216	Ergotron CPU Holder — Universal CPU Holder	44
97-582-009	Ergotron Keyboard Tray — Neo-Flex Keyboard Tray	43
97-615	Ergotron Accessories — WorkFit-A / WorkFit-S — Tall-User Kit for WorkFit Dual	36
97-616	Ergotron Accessories — WorkFit-A / WorkFit-S — Conversion Kit: LCD & Laptop to Dual	36
97-617	Ergotron Accessories — WorkFit-A / WorkFit-S — Conversion Kit: Dual to LCD & Laptop	36
97-620-060	Ergotron CPU Holder — Fatigue Floor Mat	44
97-692	Ergotron Accessories — WorkFit-A / WorkFit-S — Grommet Mount	37
97-783	Ergotron Monitor Arms — Accessories — Dual Monitor and Handle Kit	25
97-898	Ergotron Accessories — WorkFit-A / WorkFit-S — Corner Keyboard Tray	37
97-926-064	Ergotron Mobile Cart — LearnFit — Storage Bin	40
97-934	Ergotron Accessories — WorkFit-T/WorkFit-TL — WorkFit Dual Monitor Kit	38
97-935	Ergotron Accessories — WorkFit-T/WorkFit-TL — WorkFit Single LCD Monitor Kit	38
98-009-026	Ergotron Monitor Arms — HX Accessories — Triple Monitor Blow Kit	24
98-009-216	Ergotron Monitor Arms — HX Accessories — Triple Monitor Blow Kit	24
98-101-009	Ergotron Accessories — WorkFit-A / WorkFit-S — Dual Monitor Double-Hinged Bow	37
98-110	Ergotron Monitor Arms — MXV Accessories — Grommet Mount for MXV Single Monitor Arm	22

Index

Product Code	Product Description	Page
98-111	Ergotron Monitor Arms — MXV Accessories — Grommet Mount for MXV Dual Monitor Arm	22
98-478	Ergotron Monitor Arms — Accessories — Top Mount Low Profile C-Clamp	25
AAOD-S	Storage Accessories — Belong — Magnetic Divider	53
AAOP-S	Storage — Suspended Accessories — Belong — File Partition	52
AAOT-S	Storage — Suspended Accessories — Belong — Drawer Tray	52
AHDD-SU	Storage — Suspended — Belong — Security Drawer	51
ALDD-F	Storage — Suspended Accessories — Belong — Drawer Liner	52
ALTD-S	Storage — Suspended Accessories — Belong — Top Liner — Security Drawer	52
CH-8	Workstation Accessories — Hooks — UniGroup All-Purpose Hook	73
CK-3	Lock Programs — Key — HW Control Key	81
DMSP	Work Tools — Jump Stuff — Mini Shelf	68
DS-3	Workstation Accessories — Shallow Drawer	71
DTLT-2	Work Tools — Jump Stuff — Letter Tray	69
DTPR-3	Work Tools — Jump Stuff — Paper Sorter	68
DTPT-3	Work Tools — Jump Stuff — Phone Shelf	68
DTRB	Work Tools — Jump Stuff — Waste Bin	69
DTSB-3	Work Tools — Jump Stuff — Binder Bin	68
E2CH-8	Workstation Accessories — UniGroup Too All Purpose Hook	73
HUDF-F	Lock Programs — Digital Locks — Digital Lock Control Key Fob	82
HUDR-B	Lock Programs — Digital Locks — Digital Lock	82
HUDR-L	Lock Programs — Digital Locks — Digital Lock	82
HUDR-R	Lock Programs — Digital Locks — Digital Lock	82
HUDR-T	Lock Programs — Digital Locks — Digital Lock	82
HWKB-1	Lock Programs — Key — HW Key Blank	81
HWMK-1	Lock Programs — Keys — HW Master Key	81
HWSK	Lock Programs — Keys — HW Replacement Keys	81
HW-SVC	Lock Programs — Keys — HW Plugs and Keys	81
JAC-18	Workstation Accessories — Pencil Drawer	72
JRPY-3948	Waste Solutions — Recycling Station	76
KJTY-10	Storage Accessories — Belong — Personal Tray	53
KJTY-12	Storage Accessories — Belong — PDA Tray	53
KJTY-9	Storage Accessories — Belong — Pencil Tray	53
KUAH-0002	Work Tools — Magnetic Accessories — Magnet Hooks	70
KUAH-0003	Work Tools — Magnetic Accessories — Magnet Hook	70
KUAK	Work Tools — Belong — Accessory Kit	67
KUAK	Work Tools — Belong — Trays	66
KUAR-0403	Work Tools — Magnetic Accessories — Mirror	70
KUBL-2030-FJ	Work Tools — Belong — Blotter	64
KUBT	Work Tools — Belong — Base Tray	65
KUCK	Belong Monitor Arm — Accessories — Crossbar & Handle Kit	18
KUCU-0915-BNN	Work Tools — Belong — Open C Cubby	64
KUCU-1215-BNS	Work Tools — Belong — Open C Cubby	64
KUDK	Belong Monitor Arm — Accessories — Single to Dual Conversion Kit	19
KUDM	Belong Monitor Arm — Dual — Dual Monitor Arm	16
KUDP-2420	Workstation Accessories — Pencil + Drawer	71
KUHK	Belong Monitor Arm — Accessories — Single Handle Kit	18
KUHS-0000-H	Work Tools — Belong — Hanging Sorter	67
KULS	Work Tools — Belong — Desk Top L-Screen	65
KUP1-0000-CSN	Work Tools — Rails and Mounting — Rails and Mounting — Tool Rail — Single Post — C-Clamp or Thru-mount	58
KUP1-0000-USN	Work Tools — Rails and Mounting — Rails and Mounting — Tool Rail — Single Post — L-Bracket Mount	58
KUP2-0000-UBI	Work Tools — Rails and Mounting — Tool Rail — Single Post Internal/Benching	63
KUPA	Storage — Suspended — Belong — Suspended Pedestal	50
KUPD	Storage — Suspended — Belong — Suspended Pedestal	50

Index

Product Code	Product Description	Page
KUPT-0913-F	Work Tools — Belong — Paper Tray — Landscape	.66
KUPT-0913-H	Work Tools — Belong — Paper Tray — Landscape	.66
KUPY	Storage Accessories — Rails and Mounting — Slat, Wall Mount	.55
KUR1-0424-PZN	Work Tools — Rails and Mounting — Rails and Mounting — Single Side	.56
KUR1-1224-CSN	Work Tools — Rails and Mounting — Rails and Mounting — Tool Rail — Horizontal Surface Mount C-Clamp or Thru-Mount	.57
KUR1-1224-USE	Work Tools — Rails and Mounting — Rails and Mounting — Tool Rail — Single Sided Continuous Benching End	.60
KUR1-1224-USI	Work Tools — Rails and Mounting — Rails and Mounting — Tool Rail — Internal Single Sided Continuous Benching Application	.62
KUR1-1224-USN	Work Tools — Rails and Mounting — Rails and Mounting — Tool Rail — Under Horizontal Surface Mount — L-Bracket	.59
KUR2-1224-UBE	Work Tools — Rails and Mounting — Rails and Mounting — Tool Rail — Double-Sided Continuous Benching End Application Only	.61
KUR2-1224-UBI	Work Tools — Rails and Mounting — Rails and Mounting — Tool Rail — Internal Continuous Benching Application Only	.63
KURB	Waste Solutions — Recycling/Trash Bin	.76
KURC	Belong Monitor Arm — Accessories — Wire Manager Cover	.17
KURS	Work Tools — Belong — Desk Top Reference Shelf	.65
KURS-0010-H	Work Tools — Belong — Reference Shelves	.64
KURS-0012-B	Work Tools — Belong — Reference Shelves	.64
KURS-0019-H	Work Tools — Belong — Reference Shelves	.64
KUSH-0408-H	Work Tools — Belong — Mini Shelf	.66
KUSM	Belong Monitor Arm — Single — Single Monitor Arm	.14
KUSM-GROM	Belong Monitor Arm — Accessories — Grommet Mount Base	.17
KUTC-0000-H	Work Tools — Belong — Tool Cup	.67
KUTI	Belong Monitor Arm — Accessories — Belong Techbase	.17
KUTK	Belong Monitor Arm — Accessories — Triple Conversion Kit	.19
KUVK	Belong Monitor Arm — Accessories — VESA Slider Kit	.18
KUWH-0202	Workstation Accessories — Hooks — Bag Hook	.73
KUXM	Belong Monitor Arm — Single with Crossbar — Single Monitor Arm with Crossbar	.15
LSET	Lock Programs — HW Lock Plugs and Key	.80
LUTA	Lighting — Task — Adaptable LED Task Light - Add-On Kit	.46
LUTD-0017-INULDN	Lighting — Reed Premier™ — Task Light Add-On Kit	.48
LUTN	Lighting — Task — Adjustable LED Task Light - Stand-Alone	.45
LUTS-0000	Lighting — Reed Premier™ — Add-On Occupancy Sensor	.48
LUTS-0017-12ULD6	Lighting — Reed Premier™ — Starter LED Task Light	.47
LUTS-0017-19ULD5	Lighting — Reed Premier™ — Stand-Alone LED Task Light	.47
LUTT	Lighting — Task — Adjustable LED Task Light - Starter Kit	.45
LUV1	Lighting — Voyage — Without Occupancy Sensor	.49
LUV2	Lighting — Voyage — With Occupancy Sensor	.49
MAC-0001	Workstation Accessories — Make-A-Corner	.72
QBFC_F	Storage Accessories — Belong — Cushion Top	.54
SCD-19	Workstation Accessories — Steel Center Drawer	.71
TDD-MA-FS	Ergotron Monitor Mount — TRACE — Dual Monitor	.27
TDD-MA-GR	Ergotron Monitor Mount — TRACE — Dual Monitor	.27
TDD-MA-PA	Ergotron Monitor Mount — TRACE — Dual Monitor	.27
TDD-MA-PA	Ergotron Monitor Mount — TRACE — Dual Monitor	.27
TDS-MA-FS	Ergotron Monitor Mount — TRACE — Single Monitor	.26
TDS-MA-GR	Ergotron Monitor Mount — TRACE — Single Monitor	.26
TDS-MA-PA	Ergotron Monitor Mount — TRACE — Single Monitor	.26
TDS-MA-PA-251	Ergotron Monitor Mount — TRACE — Single Monitor	.26
UKMOBK	Ergotron Keyboard Tray — Keyboard Tray with Mouse Pad	.43
VZAC-0000-H	Workstation Accessories — Hooks — Compose All-Purpose Hook	.73
VZAC-0000-P	Workstation Accessories — Hooks — Compose All-Purpose Hook	.73

Product Compatibility and Limited Warranty Policy

Great Expectations

You have them as a Haworth customer and so do we. And because we value our customers, we cover our products with the Haworth North America Product Compatibility and Limited Warranty Policy.

Our Commitment To Product Compatibility – Integrated Product Platforms

As a market leader in the design and manufacture of workspaces that adapt to change, we strive to maintain product compatibility within our various generations of integrated product platforms. This benefits the customer who desires to update or modify their work environment. It also benefits the customer needing to replace a product due to damage or other reasons but which is no longer manufactured or is otherwise unavailable, such as a fabric or finish that is discontinued because of changing market preferences. In both circumstances, we often can provide products with comparable function and performance.

Our Commitment To Product Quality – The Haworth North America Limited Warranty

To ensure customer satisfaction and peace of mind, we stand behind our products with the Haworth North America Limited Warranty. To review the current version of the limited warranty including its terms and conditions, please go to:

www.haworth.com/warranty or contact OneTouch@Haworth.com or 1 877 429 6784.

Warranty Requests or Questions

For questions or service requests pertaining to the Haworth Limited Warranty, please contact your Haworth dealer.

If you are unsure who your dealer is, please contact **OneTouch@Haworth.com or 1 877 429 6784.**

Terms of Sale

The Terms of Sale apply to all products in the North America Price Lists. To review the current version of the North American Terms of Sale, please go to:

www.haworth.com/terms-of-sale or contact OneTouch@Haworth.com or 1 877 429 6784.

HAWORTH

HAWORTH® is a registered trademark of Haworth,
Inc. © Haworth, Inc. All rights reserved. 2025 12.25

haworth.com | 800 344 2600